

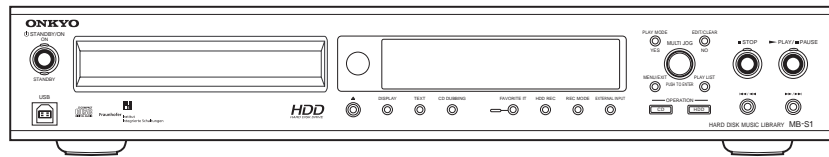

For more Hi-Fi manuals and set-up information
please visit www.hifiengine.com

ONKYO SERVICE MANUAL

Hard Disk Music Library MODEL MB-S1



Black, Silver and Titanium models

BUDD	120V AC, 60Hz
TUUP,SUUT	120-240V AC, 50/60Hz

SAFETY-RELATED COMPONENT WARNING!!

COMPONENTS IDENTIFIED BY MARK  ON THE SCHEMATIC DIAGRAM AND IN THE PARTS LIST ARE CRITICAL FOR RISK OF FIRE AND ELECTRIC SHOCK. REPLACE THESE COMPONENTS WITH ONKYO PARTS WHOSE PART NUMBERS APPEAR AS SHOWN IN THIS MANUAL.

MAKE LEAKAGE-CURRENT OR RESISTANCE MEASUREMENTS TO DETERMINE THAT EXPOSED PARTS ARE ACCEPTABLY INSULATED FROM THE SUPPLY CIRCUIT BEFORE RETURNING THE APPLIANCE TO THE CUSTOMER.

Main microprocessor version

01X04b
UDD ~#400
UUP ~#400

01X23A
Apply
UDD #401~
UUP #401~

Specifications

CD-ROM Drive Unit	ATA Packet Interface (specified in SFF-8020). (E-IDE) Industry Standard 3.5" Half Height Form Factor.
Hard Disk Drive Unit	AT Attachment 5 (ATA-5) Industry Standard 5.25" Half Height Form Factor. 40GB
D/A Converter	Single bit (Crystal CS4341, 24bit/96kHz)
A/D Converter	Single bit (Crystal CS53L32A, 24bit/96kHz)
Connections	2 Analog Output (stereo) 1 Analog Input (stereo) 2 Digital Input (optical)/(coaxial) 1 Digital Output (optical) (with Audio CD Playback only) 1 USB (Type B) 1 RS-232C (Dsub-9pin)
Frequency Response	5Hz - 20 kHz
Playback Harmonic distortion	0.007% (at 1kHz, 0dB)
Playback Dynamic range	90 dB
Playback Signal to noise ratio	90 dB
Recording Harmonic distortion	LPCM: 0.007% (at 1kHz, 0dB), MP3: 0.018% (at 1kHz, 0dB)
Recording Dynamic range	90dB
Recording Signal to Noise ratio	90dB
Channel Separation	90dB (playback)
Wow and Flutter	Below threshold of measurability
Output Level	2.0 volts r.m.s.
Power Supply Rating & Power Consumption	AC120V, 60Hz, 27W
Dimension (W.H.D.)	435 x 81 x 359 (17-1/8" x 3-3/16" x 14-1/8")
Weight	5.0kg, 11.0 lbs

Specifications and features are subject to change without notice.

SERVICE NOTE

1. Replacing the fuses



This symbol located near the fuses indicates that the fuse used is fast operating type. For continued protection against fire hazard, replace with same type fuse. For fuse rating refer to the marking adjacent to the symbol.



Ce symbole indique que le fusible utilise est a rapide. Pour une protection permanente, n'utiliser que fusibles de meme type. Ce d'ailleurs est la qu le present symbol est appse.

CIRCUIT NO.	PART NO.	DESCRIPTION
F9001	252160	FUSE, 2.5A-UL/T-237 <D>
	252076	FUSE, 3.15A-SE-EAK <T,P>

Note: <D>: 120V model only
<P>: European model only
<T>: Asian model only

2. Safety-check out (Only U.S.A. model)

After correcting the original service problem, perform the following safety check before releasing the set to the customer. Connect the insulating-resistance tester between the plug of power supply cord and screw on the back panel.

Specifications: 3.3Mohm+/-10% at 500V.

LASER WARNING LABEL

The labels shown below are affixed.

Class 1 label



Printed on rear panel

LUOKAN 1
LASERLAITE
KLASS 1
LASER APPARAT



Digital controller board & Firmware are developed and provided by QPICT, Inc.

If one of the messages shown below appears

"(Undefined)"

There is no text data or undefined name in the current track.

"Clock Adjust"

The clock of this unit has not been set.

"Copy Protect"

An attempt was made to record copyright-protected material.

"Group Full"

An attempt was made to record more than 999 groups.

"HDD Check ..."

System error occurred. Wait for a while.

"HDD Check 999"

System error occurred. Do not operate the MB-S1 until the count down is over.

"HDD Media Full"

The HDD is full.

"HDD Only"

This function is only available with HDD mode.

"HDD Track Full"

The number of tracks has reached the limit for input to the HDD.

"New Full "

An attempt was made to enter a new group that exceeds the maximum group capacity.

"No Disc"

There is no disc in the MB-S1.

"No Favorite"

There are no tracks that have a "favorite it" marking.

"No Genre"

There are no tracks that have a genre.

"No Group"

There is no group data in the HDD.

"No Playlist"

There are no play lists.

"No Track"

There are no tracks in the group; or an appropriate track was not found.

"Not Audio-CD"

The CD data format is not PCM or MP3.

"Not Available in this Source"

Will not work with the current input source.

"Not Available MP3CD"

The Rec Mode cannot be selected with CDs containing MP3 data.

"P.List Full"

An attempt was made to enter more than 100 tracks in the playlist.

"System Err...Please Power Off & On"

System error occurred. Press the STANDBY/ON button.

"Track Full"

An attempt was made to record more than 255 tracks.

MICROPROCESSOR TERMINAL DESCRIPTION

Q7502: MPD780232GC-052-8BT

PIN NO.	FUNCTION	I/O	LOGIC	DESCRIPTION	INIT	ACTIVE	SLEEP	P-OFF
1	Vdd1	-	-	+ 5V power supply	-	-	-	-
2	Vss1	-	-	GND	-	-	-	-
3	X2	-	-	Main clock (5MHz) input terminal	-	-	-	-
4	X1	-	-	Main clock (5MHz) input terminal	-	-	-	-
5	GND	-	-	GND	-	-	-	-
6	RESET	-	-	microprocessor reset terminal	-	-	-	-
7	SUBCL/SCK	I	L	Main microprocessor communication and a flash write-in clock input combination terminal	Z	Z	Z	Z
8	SUBDI/SDI	I	P	Main microprocessor communication and a flash write-in data input combination terminal	Z	Z	Z	Z
9	SUBDO/SDO	O	P	Main microprocessor communication and a flash write-in data output combination terminal	L	*	L	L
10	SUBRDY	O	H	The data ready output terminal for communication with a main microprocessor	L	*	L	L
11	NC	O		No use				
12	PHOTO	I	H	Photography mode				
13	SSCBJ	I	L	SSC rotary encoder pulse input terminal	Z	Z	Z	Z
14	SSCAJ	I	H	SSC rotary encoder pulse input terminal	Z	Z	Z	Z
15	~IRMZ	I	L	"Remote control 1 (ZONE2) signal input terminal Active""L"" "	Z	Z	Z	Z
16	FAVORITE	O		FAVORITE Light Emitting Diode output terminal				
17	STBYLED	O		STANDBY/RECEIVED output terminal				
18	GND	-	-	The GND terminal of a A/D converter	-	-	-	-
19-22	K3-K0	I	A	Main part key input terminal	-	-	-	-
23	Vss0	-	-	GND	-	-	-	-
24	+5V	-	-	The power supply terminal of a A/D converter and +5V are impressed	-	-	-	-
25	Vdd0	-	-	+ 5V power supply	-	-	-	-
26	~SYSIN	I	L	System bath input terminal	Z	Z	Z	Z
27	~SYSOUT	O	L	System bath output terminal	H	*	L	Z
28-54	P35-P9	O	H	Fluorescence display pipe segment output terminal	L	*	L	L
55-58	P8-P5	-	-	Fluorescence display pipe segment output terminal	-	-	-	-
59	Vdd2	-	-	+ 5V power supply	-	-	-	-
60	Vload	-	-	The pull down resistance connection terminal of a FIP controller	-	-	-	-
61-64	P4-P1	-	-	Fluorescence display tube segment output terminal	-	-	-	-
65-80	16G-1G	-	-	Fluorescence display tube output terminal				

MICROPROCESSOR TERMINAL DESCRIPTION

Q7004: MPD70F3033AYGC-8EU

PIN NO.	FUNCTION	I/O	LOGIC	DESCRIPTION
1	SO2	O		uPD780232(FL TUBE) Synchronous serial output terminal
2	~SCK2	I/O		uPD780232(FL TUBE) Synchronous serial CLK terminal
3	RXD1	I		RS-232C(PHAST) input terminal
4	TXD1	O		RS-232C(PHAST) output terminal
5	~WP/ACC	O		MBM29DL (flash ROM) write-protection / acceleration terminal
6	EVDD	-		An input-and-output port and positive power supply supply for combination functional terminals
7	EVSS	-		An input-and-output port and grand potential for combination functional terminals
8	RY/~BY	I		A MBM29DL (flash ROM) ready / busy terminal
9	MUTE	O	H	Muting ON/OFF terminal
10	SUBMRST	O	L	MB89580 (USB microcomputer) reset terminal (Up (S))
11	FLMRST	O	L	uPD780232 (FL microcomputer) reset terminal (Up (S))
12	USBHRST	O	L	uPD72012 (USB hub tip) reset terminal (Up (S))
13	USB D+	O	H	USB D+ control terminal (being high pull-up)
14-16	A13-A15	O		Address bus 13-15
17	CIRON/OFF	O	H	Circuit power supply ON/OFF
18	IC/VPP	-		Internal connection (it connects with VSS)
19-30	A1-A12	O		Address bus 5-12, 1-4
31	~RESET	I		System reset input
"32,33"	"XT1,XT2"	I		Oscillation connection for sub clocks
34	REGC	-		Regulator output stable capacity connection
"35,36"	"X2,X1"	I		Oscillation connection for main clocks
37	VSS	-		Ground
38	VDD	-		Positive power supply terminal
39	CLKOUT	O		Internal system clock output
40	~WRL	O	L	The low rank data light strobe signal terminal of the 16 bit data bus of external
41	~UBEN	O	L	The higher rank byte enable signal output terminal of the 16 bit data bus of external
42	~WRH	O	L	The higher rank data light strobe signal terminal of the 16 bit data bus of external
43	~RD	O	L	The lead strobe signal terminal of the 16 bit data bus of external
44	ASTB	O		The latch strobe signal output terminal of an external address bus
45	CDLED	O	H	CD LED/Program WR Start
46	HDDLED	O	H	HDD LED/Program WR Start
47-54	D0-D7	I/O		Data bus 0-7
55	BVDD	-		A bus interface and the positive power supply terminal for combination ports
56	BVSS	-		A bus interface and the grand terminal for combination ports
57-64	D8-D15	I/O		Data bus 8-15
65-70	A16-A21	I/O		Address bus 16-21
71	AVDD	-		A A/D converter and the analog positive power supply supply terminal for combination ports
72	AVSS	-		A A/D converter and the grand terminal for combination ports
73	AVREF	-		The standard voltage supply terminal for A/D converters
74				(intact) (Up (H))
75	PRVSW1	I		Destination distinction switch 1 (temporary)
76	PRVSW2	I		Destination distinction switch 2 (temporary)
77	SW1	I		Model distinction switch (L:MB-S1 H:HDR -1)
78	SW2	I	L	General-purpose switch 2 (main program forcible download switch)
79	SW3	I	L	General-purpose switch 3 (for an external ROM/RAM check)
80-85				(intact) (Up (H))
86	NMI	I		"The terminal for power failure detection (it will input, by the time it will fall completely, if voltage begins to fall) "
87	FROMA0	O		(intact)
88	D_MUTE	O		Digital output muting terminal (Up (H))
89	FLRDY	I	H	FL microcomputer data ready input terminal
90	ELVOL1			Electronic volume control terminal 1
91	ELVOL2			Electronic volume control terminal 2
92	ELVOL3			Electronic volume control terminal 3
93	GAIN_CTL	O		GAIN CTL port
94	SDA0			I2 C-bus terminal for QPICT board connection (DATA LINE) (Up (H))
95	QPINT	O	L	Interrupt QPICT board signal terminal
96	SCL0			I2 C-bus terminal for QPICT board connection (CLK LINE) (Up (H))
97	RXD0			MB89580 (USB sub microcomputer) asynchronous serial input terminal
98	TXD0			MB89580 (USB sub microcomputer) asynchronous serial output terminal
99	QPRST	O	L	QPICT reset signal terminal
100	SI2			uPD780232 (FL microcomputer) synchronous serial input terminal

The test menu operation method - 1

<How to a test menu (level 2) to enter>

1. Change unit into a standby mode.
 2. Push the DISPLAY key and the STOP key simultaneously.
 - > It is displayed on FL tube as "TEST MODE", and will be in an all-points light state in about 1 second (test mode level 1 state).
 3. Push the CD key and the HDD key.
 - > It is displayed on FL tube as "SYSTEM INIT."
- It shifts to test mode level 2 state above.

<How to slip out of a test menu (level 2)>

- When menus, such as "SYSTEM INIT", are displayed, the DISPLAY key and the STOP key are pushed simultaneously.
- > It is displayed as "NORMAL MODE" and returns to a standby state.

<Test menu outline>

SYSTEM INIT:

Initialization of a flash ROM and initialization of HDD are performed.

DOWNLOAD START:

It shifts to the software rewriting mode of a main program.

FLASH REBUILD:

The information currently recorded on HDD is reconstructed on a flash ROM.

KEY FUNCTION:

A key function is displayed (with no necessity of using it at the time of a maintenance).

VERSION:

The version of each program is displayed.

The above-mentioned menu is displayed by turning JOG after test mode shift.

The selected function is performed when JOG is pushed.

<SYSTEM INIT functional details>

[Method]

1. Choose a menu as "SYSTEM INIT" and push JOG.
2. The message of a check is displayed on FL pipe as "Really?." Please push the YES key, when you perform. Please push the NO key, when you cancel.
3. It is automatic in order of "flash initialization ->HDD initialization",
4. "INIT COMPLETE! If "is displayed, it will be completion of operation.

[Notes]

- if this function is performed, the music data currently recorded on all HDD and the inputted tag data will be disappeared and lost. Be fully careful of handling.
- When HDD is exchanged for a new one, please be sure to perform initialization of HDD and a flash ROM using this function.
 - An incorrect operation will be caused if equipment is used without performing this function.
- When the power supply of equipment falls by a certain reason while performing this function, please perform again.
 - An incorrect operation will be caused if equipment is used in the state where it is initialized halfway.

[The use pattern assumed]

- When HDD is exchanged

<DOWNLOAD START functional details>

[Methode]

1. Choose a menu as "DOWNLOAD START" and push JOG.
2. The message of a check is displayed on FL pipe as "Really?." Please push the YES key, when you perform. Please push the NO key, when you cancel.
3. The display of FL tube disappears and the CD button and the HDD button of equipment light up after a while.
4. Connect a USB cable between unit and PC and download by starting farm download software (bluefire).

[Notes]

- It becomes impossible to use unit, once it performs this function until it next finishes writing in software.
 - Since it does not usually return to processing even if it takes out and inserts AC plug, be careful of handling enough.
- Before the CD button and the HDD button light up, even if it starts farm download software (bluefire), an error is displayed and software may not start.
 - Please restart software again after waiting to switch on the light.

<FLASH REBUILD functional details>

[Methode]

1. Choose a menu as "FLASH REBUILD" and push JOG.
2. The message of a check is displayed on FL pipe as "Really?." Please push the YES key, when you perform. Please push the NO key, when you cancel.
3. Flash ROM initialization -> perform data reconstruction processing automatically.
4. "REBUILD OK! If "is displayed, it will be completion of operation.

[Notes]

- If this function is performed, since it is unrestoreable, please understand beforehand the tag information inputted into the music data currently recorded in PCM form among the tag information inputted

(Since the domain which stores tag information does not exist in the PCM file currently recorded on HDD on the relation of a file system)

- When the power supply of equipment falls by a certain reason while performing this function, please perform again.
 - An incorrect operation will be caused if equipment is used in the state where it is reconstructed halfway.
- When the music data currently recorded on HDD exists in large quantities, this thing has time in processing.
- Please do not perform this function to HDD which has not performed SYSTEM INIT processing once.
 - It is in the middle of of operation, and may hang-up.

[The use pattern assumed]

- When substrate exchange is performed

The test menu operation method - 2

<VERSION functional details>

[Real whereabouts method]

1. Combine a menu with "VERSION" and push JOG.
2. The version of each farm is displayed. A display can be changed by turning JOG.

The contents displayed are as follows.

- Main
Soft version number currently recorded on the external flash ROM (whole charge of operation)
- Boot
Soft version number currently recorded in CPU (V850) of a main board (starting processing charge)
- Disp
Soft version number currently recorded on CPU of a display board (display processing charge)
- USB
Soft version number currently recorded in CPU (MB89) of a main board (USB communication charge)
- The soft version number currently recorded on the QP-B....
QP ICT board (device control charge)

Please push the MENU/EXIT key, when you escape from this mode.

[Notes]

- When you check the version of QP ICT software (QP-B), please reboot unit.
Please perform this function again and check a version, after performing "POWER ON-> standby state ->OFF."

EXPLODED VIEW

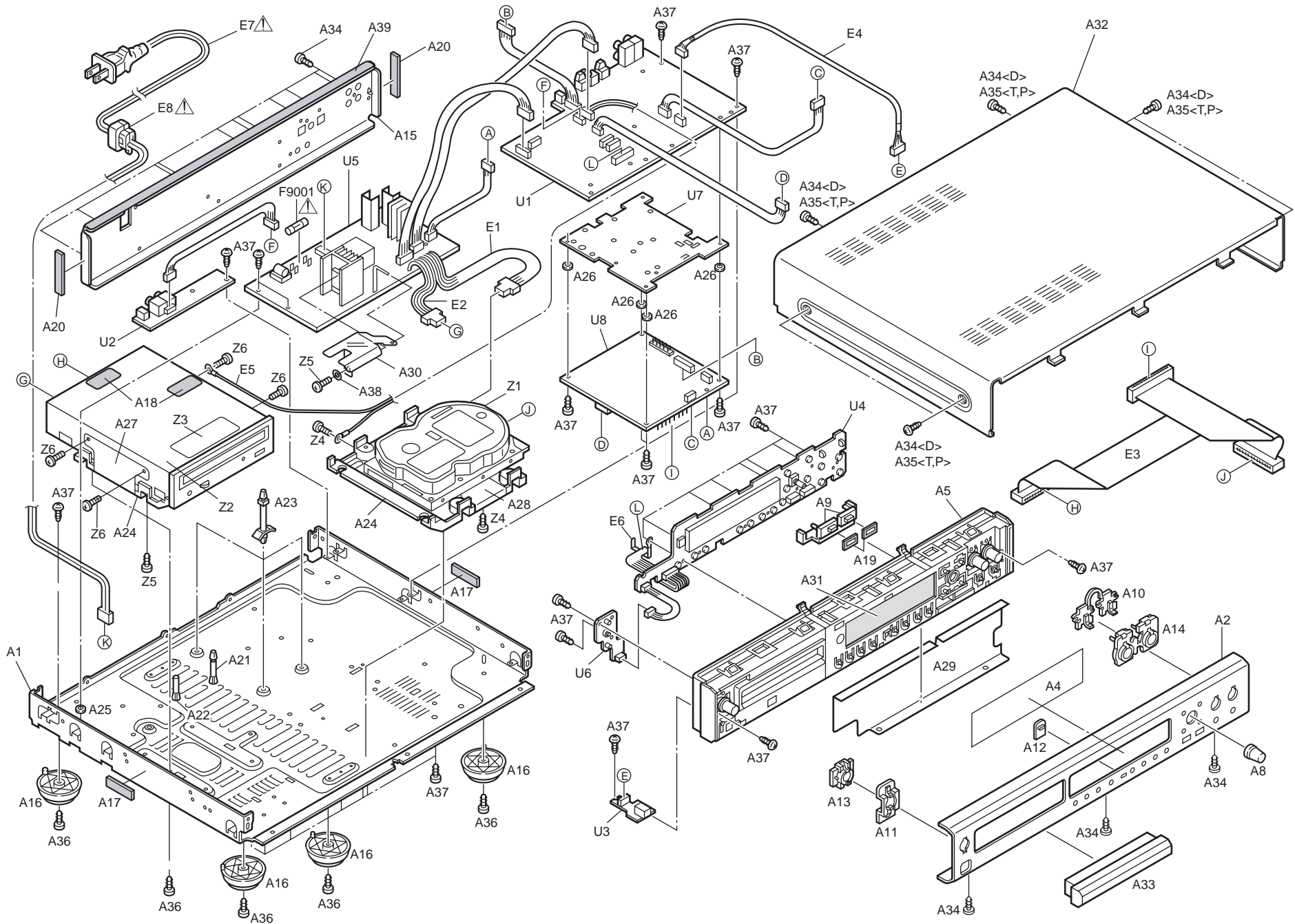

EXPLODED VIEWS - PARTS LIST

No.	Description	Part number	No.	Description	Part number
U1	PC BOARD AS,NAAR-7346-1A	1W225546-1A	A18	CUSHION	28141491
U2	PC BOARD AS,NAETC-7347-1A	1W225547-1A	A19	CUSHION	28141486
U3	PC BOARD AS,NAETC-7348-1A	1W225548-1A	A20	CUSHION	28141467
U4	PC BOARD AS,NADIS-7349-1A	1W225549-1A	A21	HOLDER,KGLS-18RF	27190657
U5	PC BOARD AS,NAPS-7350-1A	1W225564-1A <D>	A22	HOLDER,KGPS-18RF	27190926
	PC BOARD AS,NAPS-7350-1B	1W225564-1B <T,P>	A23	HOLDER,KGLS-18S	27190470
U6	PC BOARD AS,NASW-7351-1A	1W225551-1A	A24	HOLDER(CD)	27191160A
U7	PC BOARD AS,NAETC-7359-1A	1W225564-1A	A25	SPACER	27270429
U8	PC BOARD AS,NQP3100D	24150024	A26	SPACER,PVC T1.0	27270427
E1	SOCKET AS,NSAS-8P0963	2009990694	A27	ISO PLT(CD)	28175281
E2	SOCKET AS,NSAS-8P0964	2009990695	A28	ISO PLT(HDD)	28175282
E3	SOCKET AS,NSAS-120P0962	2009990693	A29	ISO PLT(CU)	28175280
E4	SOCKET AS,NSAS-8P0983	2009990706	A30	ISO PLT(HS)	28175283
E5	CRIMP AS,SRA-STRIP(300)	20799132	A31	B PLATE	28133400 <D>
E6	CLIP,CS-1U	27255004	A32	COVER	28184821 <D>
E7	AC CORD,AS-UC-2#18	▲ 253279HDK <D>			28184820 <T,P>
	AC CORD,AS-CEE or	▲ 253193HIT or <T,P>	A33	DOOR	28148500 <D>
	AC CORD,AS-CEE	▲ 253313HRK <T,P>			28148498 <T>
E8	BUSHING,S-RELIEF #2271	▲ 27300750			28148499 <P>
F9001	FUSE,2.5A-UL/T-237	▲ 252160 <D>	A34	SCREW,3TTB+8B(BC)	838430088
	FUSE,3.15A-SE-EAK	▲ 252076 <T,P>	A35	SCREW,3TTB+8B(UN)	838930088 <T,P>
A1	CHASSIS	27100407A	A36	SCREW,3TTW+8B(BC)	831430088
A2	F PANEL	27212357 <D>	A37	SCREW,3TTB+8B	838130088
		27212355 <T>	A38	SP WASHER,SE-3(BC)	871430
		27212356 <P>	A39	TAPE(CROSS-8U)	29110082
A3	BADGE	28135244Y <D>	Z1	Hard Disk Drive,MPG3204AT-EF	24842001
A4	CLEAR PLT	28191950 <D>	Z2	CD-ROM MECHA,CR-594-C	24800049
		28191946 <T>	Z3	LABEL	29362285
		28191947 <P>	Z4	SCREW,No.6-32*1/4UNC	801603
A5	F BRACKET	27111255 <D>	Z5	SCREW,3P+10FN(BC)	82143010
		27111253 <T>	Z6	SCREW,3P+6FN(BC)	82143006
		27111254 <P>			
A8	KNOB(AMCS)	28325930 <D>			
		28325967 <T>			
		28325968 <P>			
A9	FACET(HDD,CD)	28198941			
A10	FACET(STOP)	28198928			
A11	FACET(STANDBY)	28198930			
A12	FACET(FAVORITE)	28198940			
A13	GUIDE(STANDBY)	27268049 <D>			
		27268047 <T>			
		27268048 <P>			
A14	GUIDE(STOP)	27268053 <D>			
		27268057 <T>			
		27268058 <P>			
A15	REAR PANEL	27122920 <D>			
		27122919 <T,P>			
A16	BOTTOM LEG(AS)	27175388			
A17	CUSHION(SHLD)	28141490			

Note: <D>: 120V model only
 <P>: European model only
 <T>: Asian model only

SAFETY-RELATED COMPONENT WARNING!!

COMPONENTS IDENTIFIED BY MARK ▲ ARE CRITICAL FOR RISK OF FIRE AND ELECTRIC SHOCK. REPLACE THESE COMPONENTS WITH ONKYO PARTS WHOSE PART NUMBERS APPEAR AS SHOWN IN THIS MANUAL.

SCHEMATIC DIAGRAM (NAAR-7346) -1

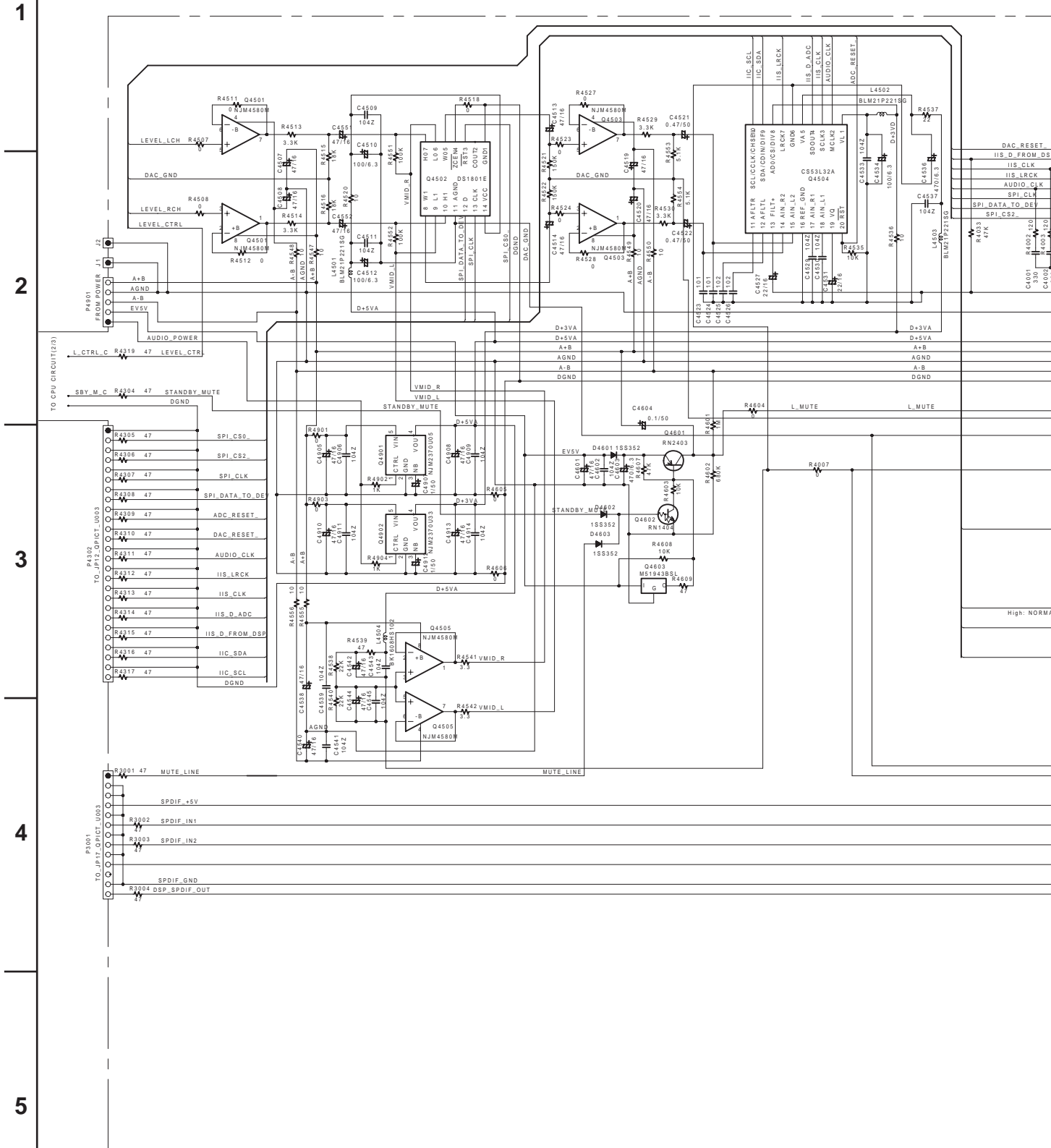

High: NORMA

A

B

C

D

SCHEMATIC DIAGRAM (NAAR-7346) -2

1

2

3

4

5

NAAR-7346

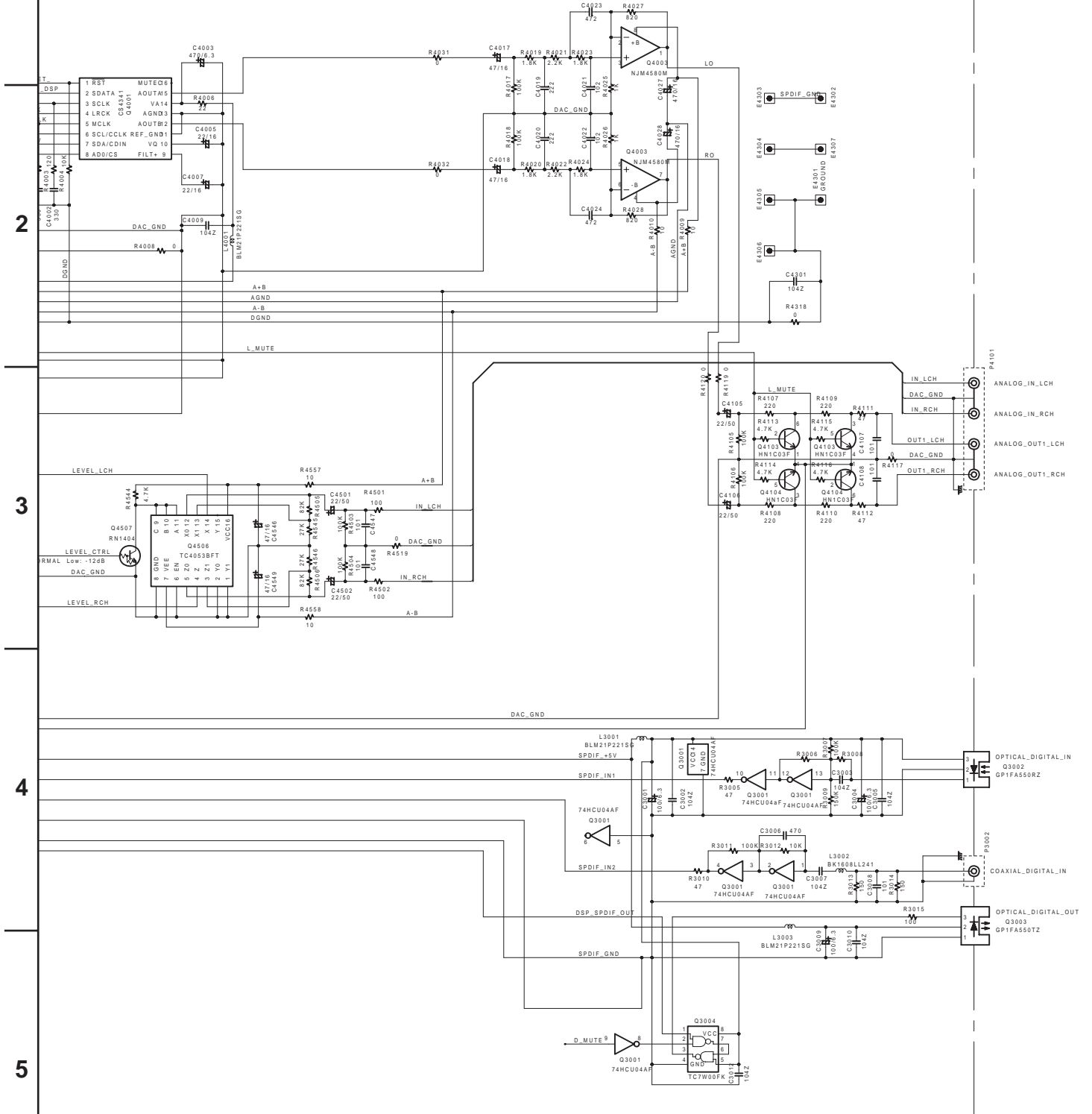

SCHEMATIC DIAGRAM (NAAR-7346) -3

1

2

3

4

5

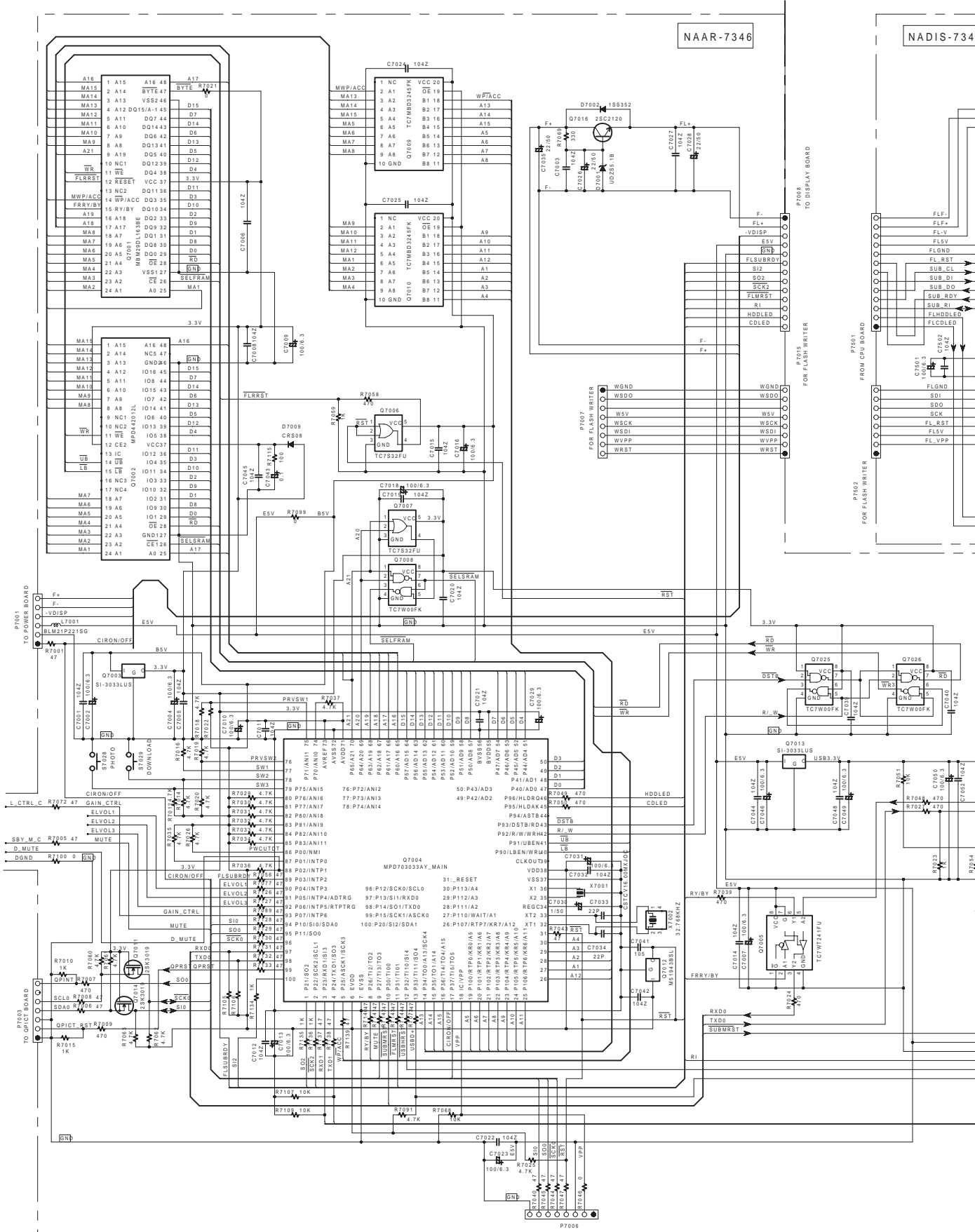

A

B

C

D

SCHEMATIC DIAGRAM (NAAR-7346) -4

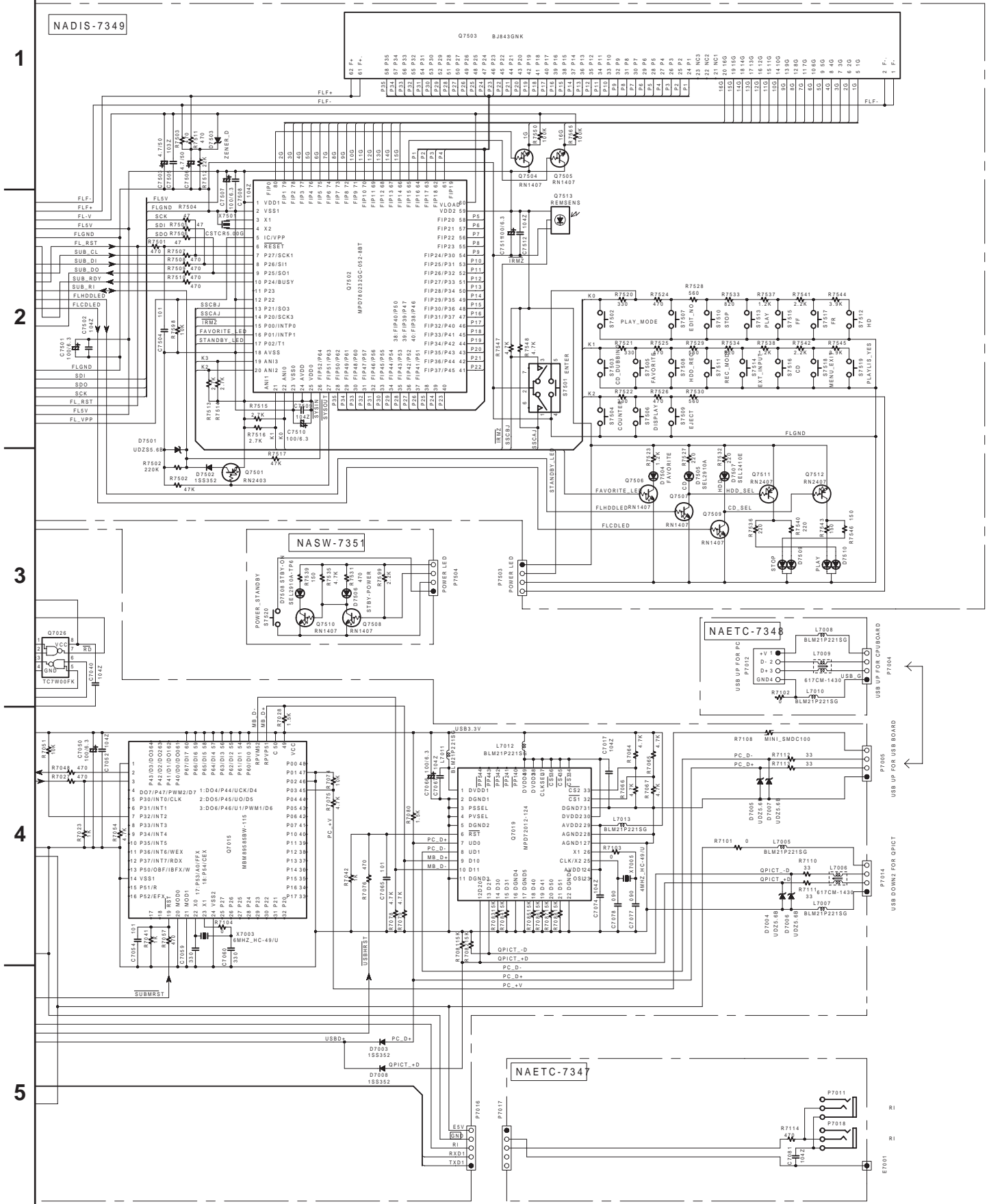

SCHEMATIC DIAGRAM (NAPS-7350:<D>) -1

1 NAPS-7350

2

3

4

5

L91
1C

L9
1C

L91
1C

L9
1C

L9007

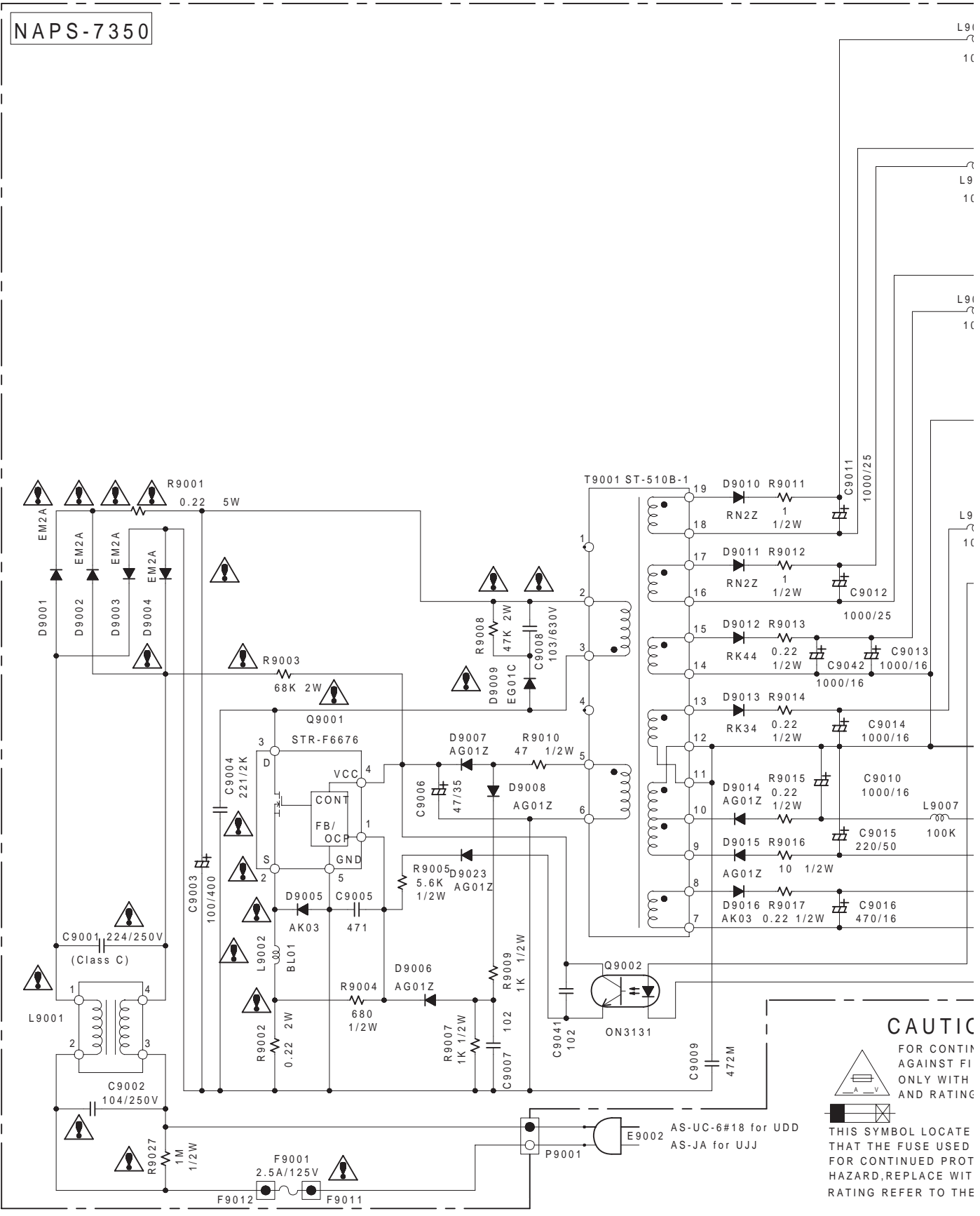

CAUTIC
 FOR CONTIN
 AGAINST FI
 ONLY WITH
 AND RATING



THIS SYMBOL LOCATE
 THAT THE FUSE USED
 FOR CONTINUED PROT
 HAZARD, REPLACE WIT
 RATING REFER TO THE

E9002 AS-UC-6#18 for UDD
 AS-JA for UJJ

A **B** **C** **D**

SCHEMATIC DIAGRAM (NAPS-7350:<D>) -2

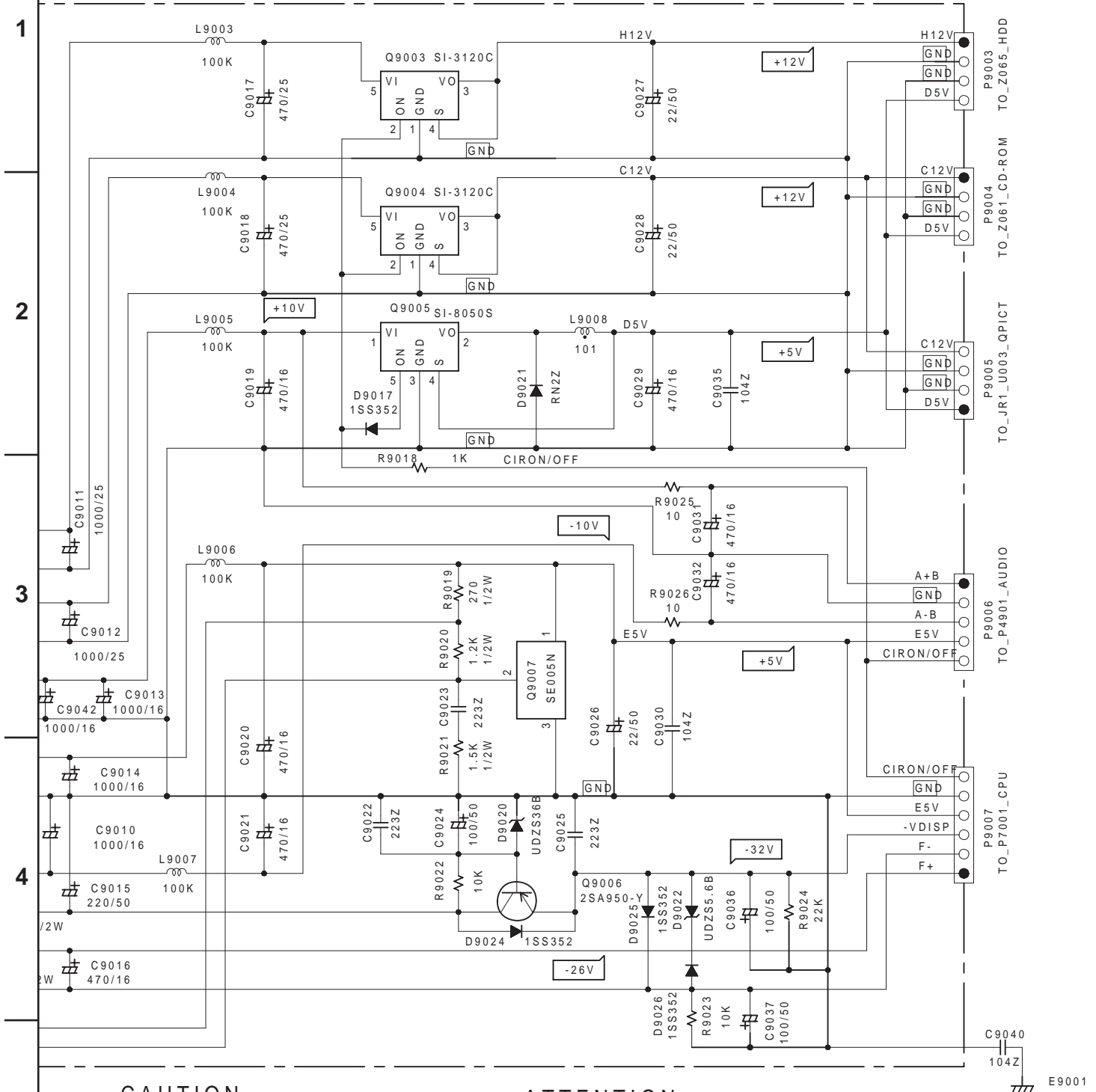

CAUTION

FOR CONTINUED PROTECTION AGAINST FIRE HAZARD, REPLACE ONLY WITH FUSE OF SAME TYPE AND RATING INDICATED.



THIS SYMBOL LOCATED NEAR THE FUSE INDICATES THAT THE FUSE USED IS SLOW OPERATING TYPE FOR CONTINUED PROTECTION AGAINST FIRE HAZARD, REPLACE WITH SAME TYPE FUSE. FOR FUSE RATING REFER TO THE MARKING ADJACENT TO THE SYMBOL.

ATTENTION

AFIN D'ASSURER UNE PROTECTION PERMANENTE CONTRE LES RISQUES D'INCENDIE, REMPLACER UNIQUEMENT PAR UN FUSIBLE DE MEME TYPE ET CALIBRATION COMME INDIQUE.

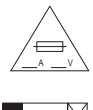

CE SYMBOLE INDIQUE QUE LE FUSIBLE UTILISE EST LENT. POUR UNE PROTECTION PERMANENTE, N'UTILISER QUE DES FUSIBLES DE MEME TYPE. CE DERNIER EST INDIQUE LA QU LE PRESENT SYMBOLE EST APPOSE.

5

E9001

SCHEMATIC DIAGRAM (NAPS-7350:<T,P>) -1

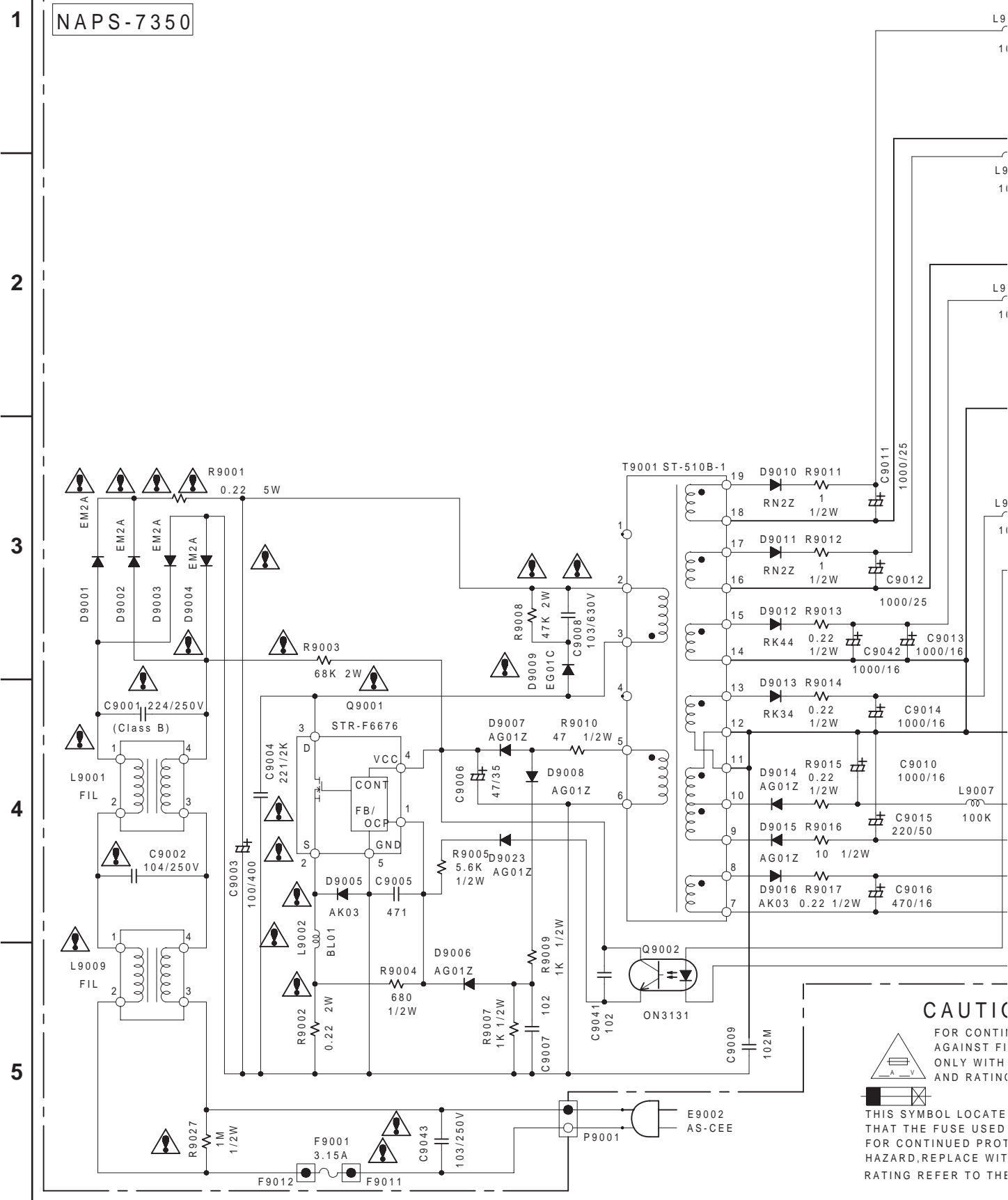

CAUTION

FOR CONTI
AGAINST FI
ONLY WITH
AND RATING



THIS SYMBOL LOCATE
THAT THE FUSE USED
FOR CONTINUED PROT
HAZARD, REPLACE WIT
RATING REFER TO THE

A B C D
SCHEMATIC DIAGRAM (NAPS-7350:<T,P>) -2

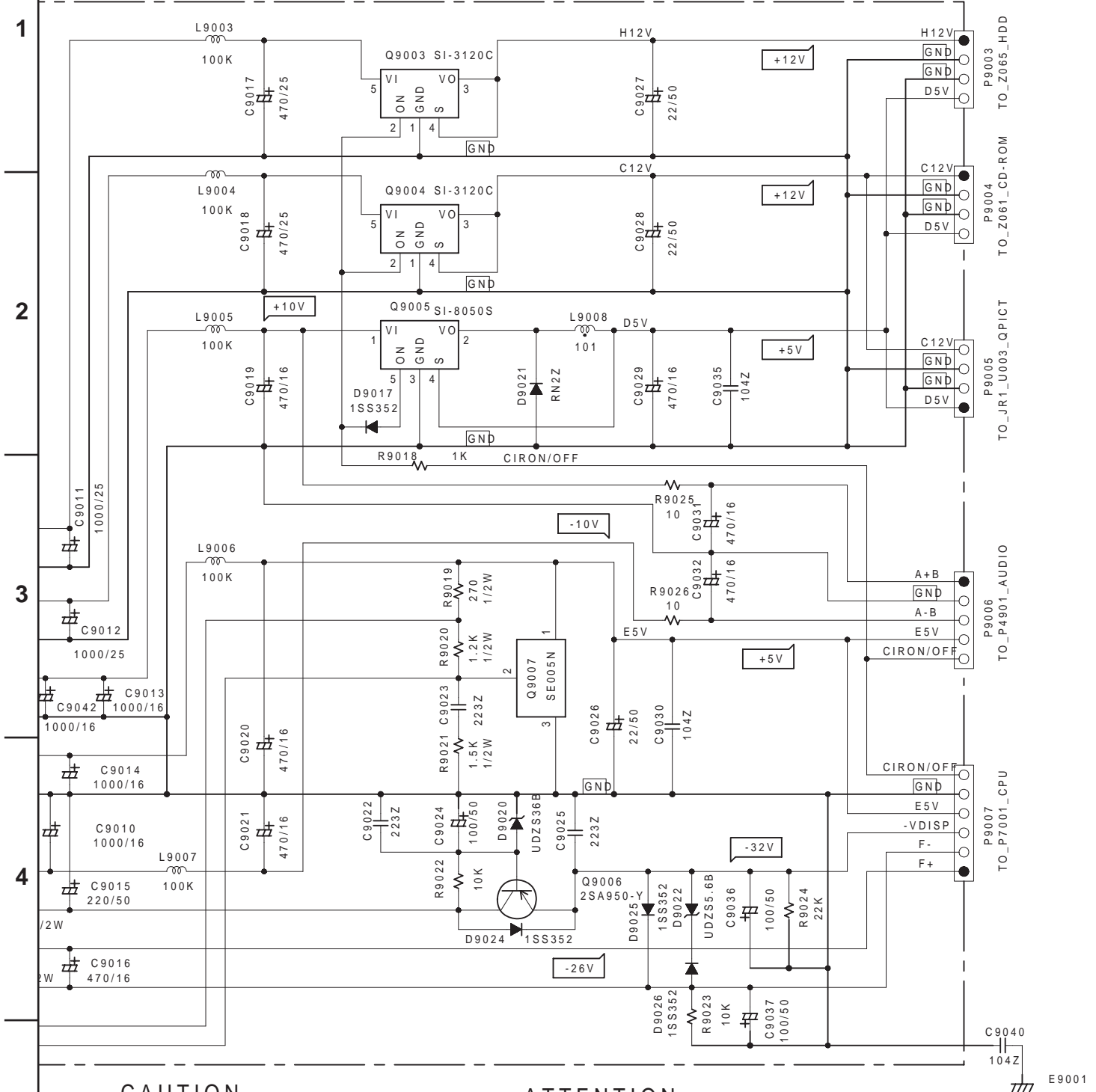

CAUTION

FOR CONTINUED PROTECTION AGAINST FIRE HAZARD, REPLACE ONLY WITH FUSE OF SAME TYPE AND RATING INDICATED.



THIS SYMBOL LOCATED NEAR THE FUSE INDICATES THAT THE FUSE USED IS SLOW OPERATING TYPE FOR CONTINUED PROTECTION AGAINST FIRE HAZARD, REPLACE WITH SAME TYPE FUSE. FOR FUSE RATING REFER TO THE MARKING ADJACENT TO THE SYMBOL.

ATTENTION

AFIN D'ASSURER UNE PROTECTION PERMANENTE CONTRE LES RISQUES D'INCENDIE, REMPLACER UNIQUEMENT PAR UN FUSIBLE DE MEME TYPE ET CALIBRATION COMME INDIQUE.



CE SYMBOLE INDIQUE QUE LE FUSIBLE UTILISE EST É LENT. POUR UNE PROTECTION PERMANENTE, N'UTILISER QUE DES FUSIBLES DE MEME TYPE. CE DARNIER EST INDIQUE LA QU LE PRESENT SYMBOLE EST APPOSE.

5

PACKING VIEW

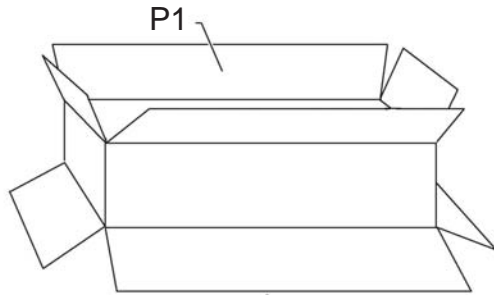
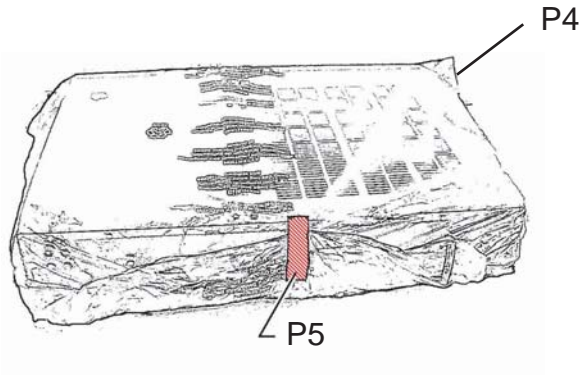

Accessories A'ssy (com)

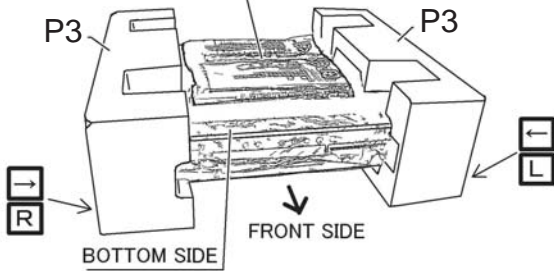

P6
PP TAPE (BOTTOM SIDE)

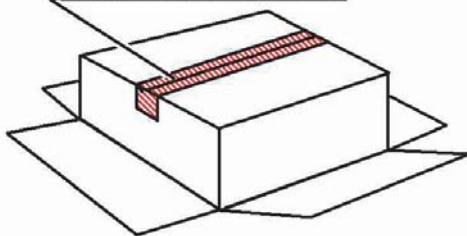

P6
PP TAPE (TOP SIDE)

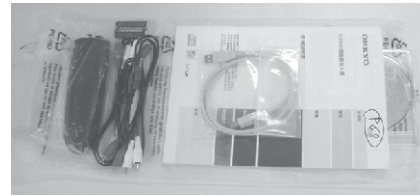
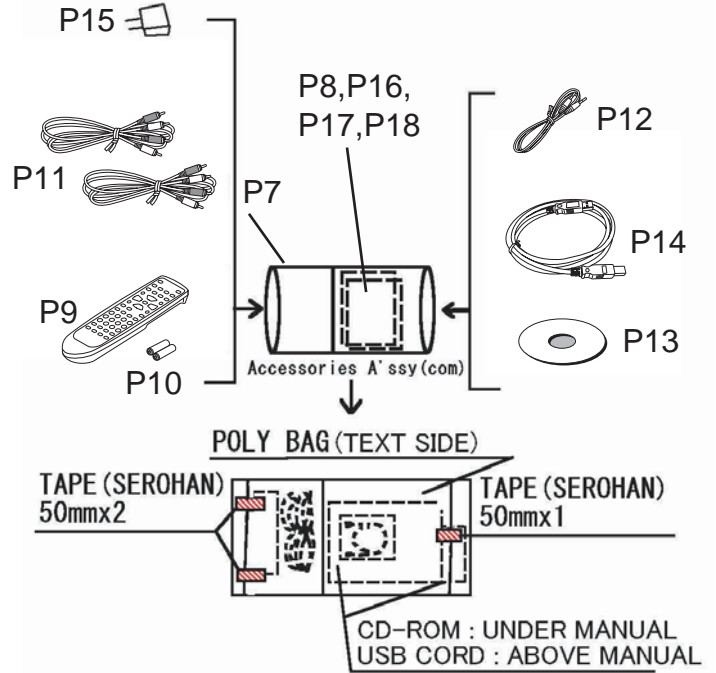
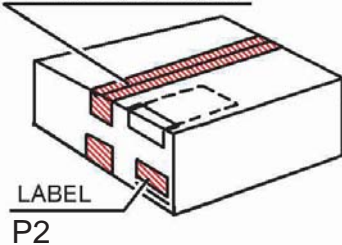

No.	Description	Part number
[PACKING]		
P1	CARTON	29053824 <D> 29053826 <T> 29053825 <P>
P2	UPC LABEL EAN LABEL EAN LABEL	29362970 <D> 29362971 <T> 29362973 <P>
P3	PAD AS	29092031B
P4	POLY BAG (700x600)	29100141A
P5	TAPE, (SEROHAN)NITTO NO.29	29110149
P6	TAPE,NITTO 3301	29110141
[ACCESSARY]		
P7	POLY BAG (350x200xW250)	29100201
P8	WARRANTY CARD	29365083B <D>
P9	REMOTE CONTROL UNIT, RC-459P	24140459
P10	BATTERY,UM-3	3010054
P11	PIN-CORD AS or PIN CORD AS	2010098A or 2010326
P12	CORD AS (R1)	2010200
P13	CD-ROM (MB-S1)	292174A
P14	CORD AS (USB-1M)	2010391
P15	CV PLUG,CV-K-2	25055911 <T>
P16	INS MANUAL,E(MB-S1)	29343221A
	INS MANUAL,Ct(MB-S1)	29343223 <T>
	INS MANUAL,G(MB-S1)	29343275 <P>
	INS MANUAL,F(MB-S1)	29343276 <P>
	INS MANUAL,I(MB-S1)	29343277 <P>
P17	INST SHEET,MB-S1(HDD-E)	29355373
P18	INST SHEET,MB-S1(U3)	29355376 <P>

A

B

C

D

PC BOARD VIEW - 5

U5:NAPS-7350 (Bottom Side View from Top Side)

1

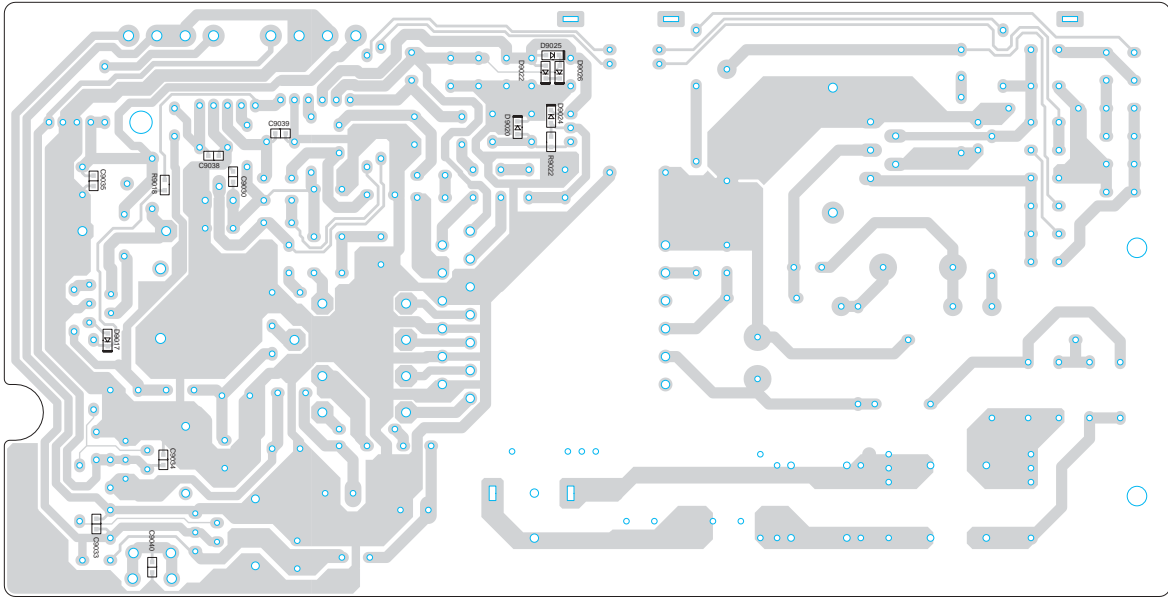

2

U5:NAPS-7350 (Top Side View from Bottom Side)

3

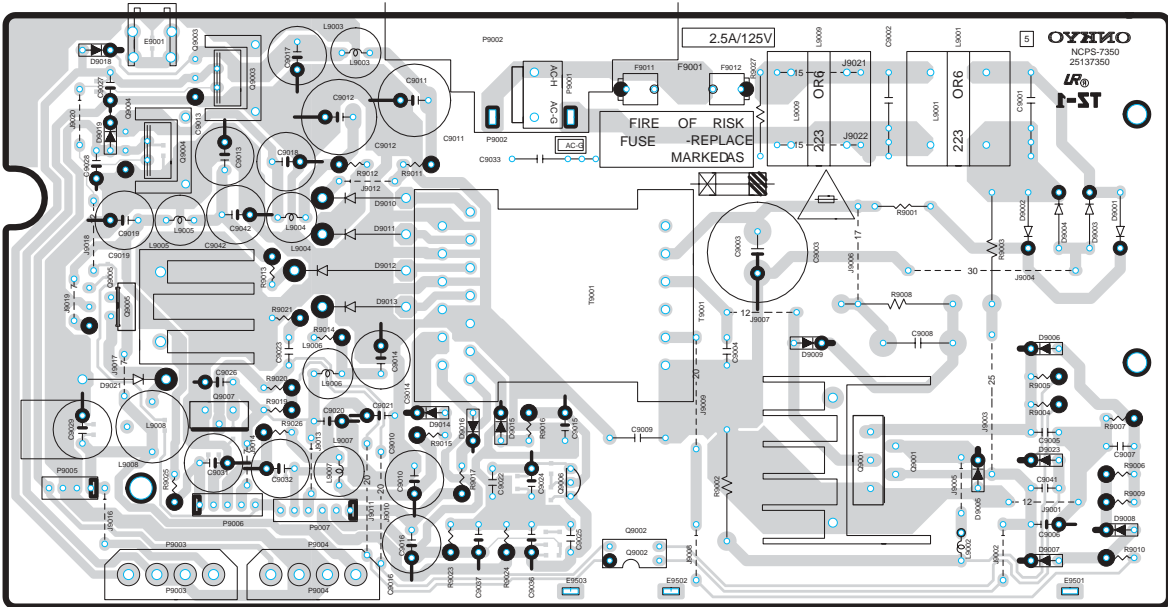

4

U6:NASW-7351

5

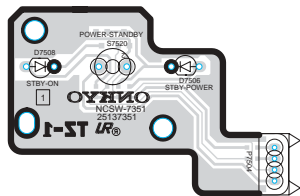

(Top Side View from Bottom Side)

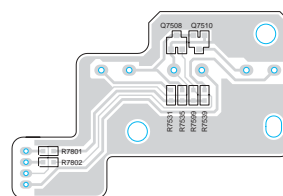

(Bottom Side View from Top Side)

A

B

C

D

E

PC BOARD VIEW - 4 U4:NADIS-7349

(Bottom Side View from Top Side)

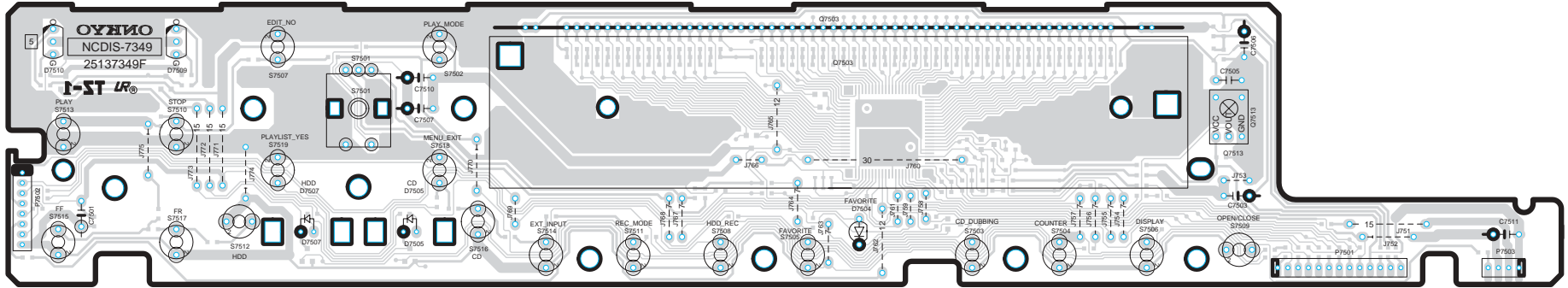

1

2

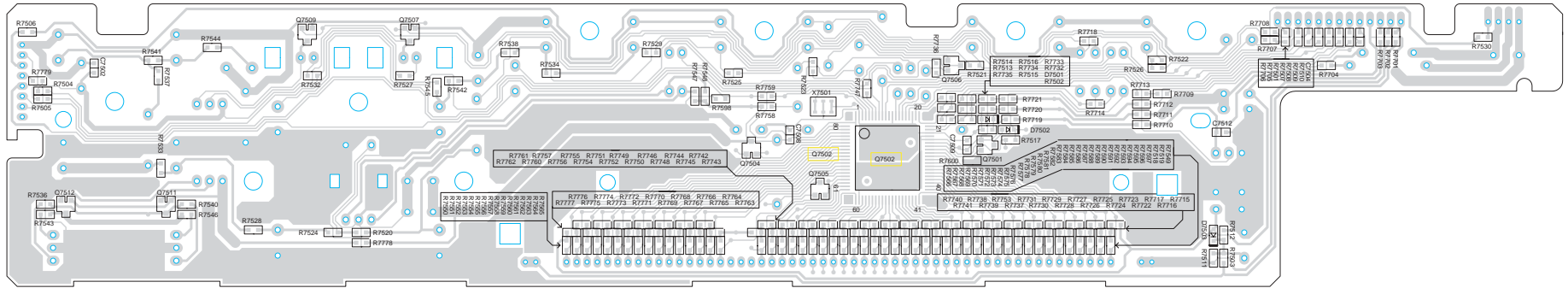

3

(Top Side View from Bottom Side)

4

A

B

C

D

E

PC BOARD VIEW - 3

1

U2:NAETC-7347 (Top Side View from Bottom Side)

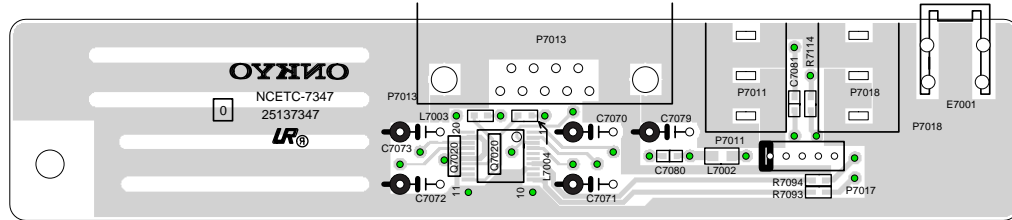

2

U3:NAETC-7348 (Top Side View from Bottom Side)

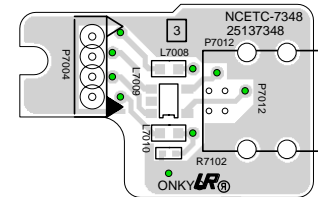

3

U2:NAETC-7347 (Bottom Side View from Top Side)

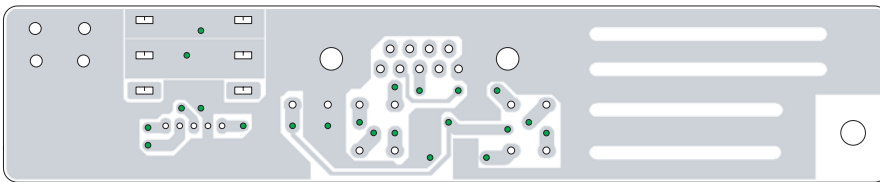

4

U3:NAETC-7348 (Bottom Side View from Top Side)

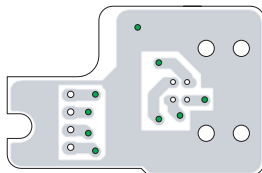

A

B

C

D

E

PC BOARD VIEW - 2
U1:NAAR-7346 (Bottom Side View from Top Side)

1

2

3

4

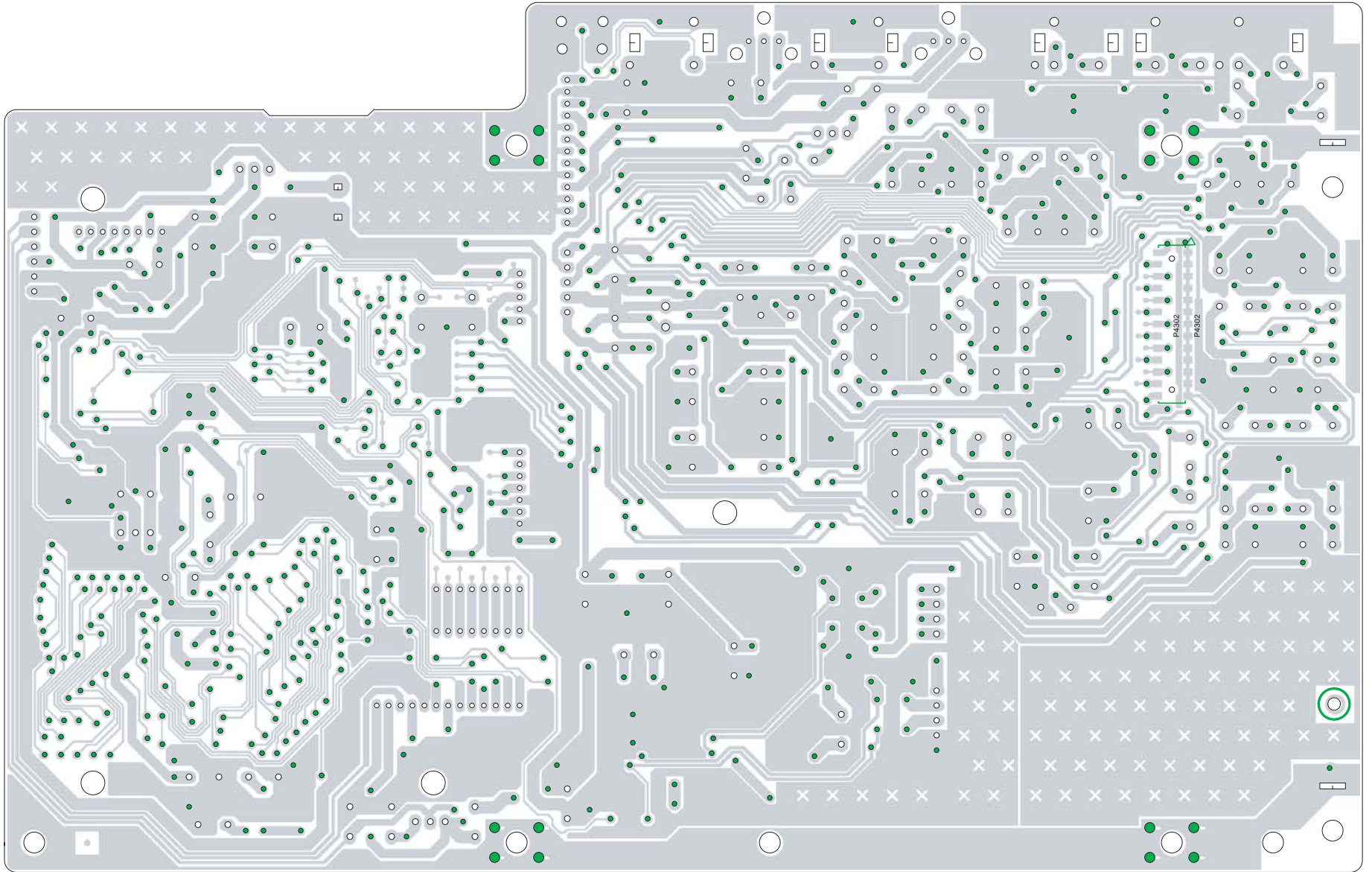

PRINTED CIRCUIT BOARD PARTS LIST-1

NAAR-7346			C-No	Description	Part number
C-No	Description	Part number	[RESISTOR]		
[SEMI CONDUCTOR]			R7108	RESISTOR,miniSMDC100	4000192R2
D4601,D4602, D4603	C-DIODE,1SS352	223234R2	[SW TRM] E4302	TRM(SCREW), NEGITANSI M3	25065425
D7001	ZENER D,UDZS5.1B	224550510R2	E4303-E4306	TRM,NTM-1P232(M1700)	25060301
D7002,D7003	C-DIODE,1SS352	223234R2	E4311,E4312	HOLDER,(CRAMP) UA-0 V0	27190608-1
D7004-D7007	ZENER D,UDZS5.6B	224550560R2	P3001	SOCKET AS,NSAS-26P0971	2009990696A
D7008	C-DIODE,1SS352	223234R2	P3002	PIN JACK,NPJ-1PDOR369	25045548
D7009	DIODE,CRS08	223272R2	P4101	PIN JACK,NPJ-4PDWR405	25045594
Q3001	IC,74HCU04F	222740046R2	P4302	SOCKET,NSCT-26P2543	25052646
Q3002	PHT CP,GP1FA550RZ	24120083	P4901	PLUG,NPLG-5P119	25055135
Q3003	PHT CP,GP1FA550TZ	24120082	P7001	PLUG,NPLG-6P120	25055136
Q3004	IC,TC7W00FK	22241707R2	P7003	SOCKET-AS,NSAS-14P0180	2002391425
Q4001	IC,CS4341	22241701R2	P7005	PLUG,NPLG-4P118	25055134
Q4003	IC,NJM4580M-D	22241448R2	P7006	PLUG,NPLG-8P660	25055704
Q4103,Q4104	TR,HN1C03F-B	2216141R2Y	P7008	PLUG,NPLG-13P141	25055157
Q4501	IC,NJM4580M-D	22241448R2	P7014	SOCKET AS,NSAS-8P0969	20019240815
Q4502	IC,DS1801E	22241702R2	P7016	PLUG,NPLG-5P133	25055149
Q4503	IC,NJM4580M-D	22241448R2	S7028,S7029	PUSH SW,NPS-111-S662	25035699
Q4504	IC,CS53L32A	22241703R2			
Q4505	IC,NJM4580M-D	22241448R2			
Q4506	IC,4053BFT(TC4053BFT)	222840533R2TO	NAETC-7347		
Q4507	TR,RN1404	2214490R2	C-No	Description	Part number
Q4601	TR,RN2403	2214540R2	[SW TRM]		
Q4602	TR,RN1404	2214490R2	E7001	TRM(SCREW), NEGITANSI M3	25065425
Q4603	IC,M51943B	222951	P7011	JACK,HSJ0847-01-010	25045204
Q4901	IC,NJM2370U05	22241289R2	P7017	SOCKET-AS,NSAS-10P0034	2002341020
Q4902	IC,NJM2370U33	22241547R2	P7018	JACK,HSJ0847-01-010	25045204
Q7001	IC,MBM29DL163BE or IC,MBM29DL163BD	22241736R3 or 22241737R3			
Q7002	IC,MPD442012	22241705R3	NAETC-7348		
Q7003	IC,SI-3033LUS	22278033CR2	C-No	Description	Part number
Q7004	IC,MPD70F3033AYGC-8EU	22241719R3	[TRANS COIL]		
Q7005	IC,TC7WT241FU	22241546R2	L7008	CHOKO COIL,BLM21P221SG	230949R2
Q7006,Q7007	IC,TC7S32FU	22241292R2	L7009	CHOKO COIL,NCH-1571	233530R2
Q7008	IC,TC7W00FK	22241707R2	L7010	CHOKO COIL,BLM21P221SG	230949R2
Q7009,Q7010	IC,TC7MBD3245FK	22241709R2	[SW TRM]		
Q7011	TR,2SK3019	2216520R2	P7004	PLUG,NPLG-4P118	25055134
Q7012	IC,M51943B	222951	P7012	SOCKET,NSCT-4P2042	25052145
Q7013	IC,SI-3033LUS	22278033CR2			
Q7014	TR,2SK3019	2216520R2	NADIS-7349		
Q7015	IC,MB89585BW-115	22241708R3	C-No	Description	Part number
Q7016	TR,2SC2120-O or TR,2SC2120-Y	2211163 or 2211164	[TUNER UNIT]		
Q7019	IC,MPD72012-124-3B4	22241632R3	Q7513	REMO SENS,SPS-440-1-N	241339
Q7025,Q7026	IC,TC7W00FK	22241707R2	[SEMI CONDUCTOR]		
[TRANS COIL]			D7501	ZENER D,UDZS5.6B	224550560R2
L3001	CHOKO COIL,BLM21P221SG	230949R2	D7502	C-DIODE,1SS352	223234R2
L3002	EMIFIL,BK1608LL241-T	230959R1	D7504	LED,SEL2410E-1	225302
L3003,L4001, L4501-L4503	CHOKO COIL,BLM21P221SG	230949R2	D7505	LED,SEL2910A	225259
L4504	EMIFIL,BK1608HS102-T	230955R2	D7507	LED,SEL2410E	225258
L7001,L7005	CHOKO COIL,BLM21P221SG	230949R2	D7509,D7510	LED,SML79423C-TP15	225392
L7006	CHOKO COIL,NCH-1571	233530R2	Q7501	TR,RN2403	2214540R2
L7007	CHOKO COIL,BLM21P221SG	230949R2	Q7502	IC,MPD780232GC-052-8BT	22241697R3
L7011-L7013	CHOKO COIL,BLM21P221SG	230949R2	Q7503	FL TUBE,BJ843GNK	212225
X7001	CERA LOCK, CSTCV16.00MXJ0C	3010329R2	Q7504-Q7507, Q7509	TR,RN1407	2216260R2
X7002	CRYSTAL,DMX-26S32.768KHz	3010360R2	Q7511,Q7512	TR,RN2407	2216360R2
X7003	CRYSTAL,HC-49/U03 6MHz	3010349	X7501	CERA LOCK, CSTCR5M00G53-B0	3010356R2
X7005	CRYSTAL,HC-49/U03 4MHz	3010350	[SW TRM]		
[CAPACITOR]			E7501	HOLDER,(FL)	27191082
C7043	EDL C,DX-5R5L104	3000078	E7502,E7503	HOLDER,(LED)	27191150
C4003	ELECT C,CE04W6.3V-470M	354724719	P7501	SOCKET AS,NSAS-26P0800	2002A392640
C4027,C4028	ELECT C,CE04W16V-470M	354744719	P7503	SOCKET-AS,NSAS-8P0309	2002390815
C4536,C4603	ELECT C,CE04W6.3V-470M	354724719	S7501	ROT ENC,EC11B15244	25065507
C4019,C4020	TF C,ECQ-B50V-222J	374722224	S7502-S7519	PUSH SW,NPS-111-S662	25035699
C4021,C4022	TF C,ECQ-B50V-102J	374721024			
C4023,C4024	TF C,ECQ-B50V-472J	374724724			

PRINTED CIRCUIT BOARD PARTS LIST-2

NAPS-7350			C-No	Description	Part number
C-No	Description	Part number	R9024	METAL O R,RS1/2WBJ-10K	443521034
[SEMI CONDUCTOR]			R9025,R9026	METAL O R,RS1/2WBJ-10	443521004
D9001-D9004	DIODE,EM2A	△ 22380287F	R9027	△ RESISTOR,RD1/2SPH-1M	4000205
D9005	DIODE,AK03	△ 22380310	[SW TRM]		
D9006-D9008	DIODE,AG01Z	22380294	E9001	TRM(SCREW),NEGITANSI M3	25065425
D9009	DIODE,EG01C	△ 22380291	E9503	WS CLAMP,CP-1S	260224
D9010,D9011	DIODE,RN2Z	22380295F	E9801	FUSE LABEL,T3.15AL250V	29362779 <T,P>
D9012	DIODE,RK44	22380311F	F9011,F9012	FUSE HOL,NSCT-1P2031	25052133
D9013	DIODE,RK34F	223189F	P9001	PLUG,NPLG-2P631	25055675
D9014,D9015	DIODE,AG01Z	22380294	P9003,P9004	PLUG,NPLG-4P1045	25056106
D9016	DIODE,AK03	22380310	P9005	SOCKET AS,NSAS-8P0965	20019290825
D9017	C-DIODE,1SS352	223234R2	P9006	SOCKET AS,NSAS-10P0966	20019291020
D9020	ZENER D,UDZS33B	224553300R2 <D,T>	P9007	SOCKET AS,NSAS-12P0967	20019291210
	ZENER D,UDZS36B	224553600R2 <P>	Q9001A	HEAT SINK,RAD-160	27160494
D9021	DIODE,RN2Z	22380295F	Q9001B	SCREW,3P+10FN(BC)	82143010
D9022	ZENER D,UDZS5.6B	224550560R2	Q9001C	ISO PLT,(HS)	28175283
D9023	DIODE,AG01Z	22380294	Q9001D	SP WASHER,SW-3(BC)	871430
D9024-D9026	C-DIODE,1SS352	223234R2	Q9003A,Q9004A	RADIATOR,RAD-95(B)	27160315
Q9001	IC,STR-F6676	△ 22241698	Q9003B,Q9004B	SCREW,3P+6FN(BC)	82143006
Q9002	PHT CPL,ON3131-R	24120044	Q9005A	HEAT SINK,RAD-159	27160493
Q9003,Q9004	IC,SI-3120C	22241699	Q9005B	SCREW,3P+10FN(BC)	82143010
Q9005	IC,SI-8050S	22241700			
Q9006	TR,2SA950-Y	2211504			
Q9007	IC,SE005N	22241233			
[TRANS COIL]			NASW-7351		
L9001	CHOKE COIL,NCH-3561	△ 231280 <D>	C-No	Description	Part number
	CHOKE COIL,NCH-1560	△ 231279 <T,P>	[SEMI CONDUCTOR]		
L9002	FR CORE,BL02RN1-R62	△ 230905	D7506	LED,SEL2210S1	225297
L9003-L9007	CHOKE COIL,NCH-1490	231253K100	D7508	LED,SEL2910A-TP6	225390
L9008	CHOKE COIL,NCH-3582K101	231303K101	Q7508,Q7510	TR,RN1407	2216260R2
L9009	CHOKE COIL,NCH-1560	△ 231279 <T,P>	[SW TRM]		
T9001	P TRANS,NPT-1428	2301560A	P7504	PLUG,NPLG-4P132	25055148
[CAPACITOR]			S7520	PUSH SW,NPS-111-S662	25035699
C9001	ET C,QETJ5224KRPT	△ 3300057 <D>			
	MKP C,MKP R46 224M	△ 3300058 <T,P>			
C9002	ET C,QETJ5104KRPT	△ 3300056			
C9003	AXW C,CE04W400V-100M	△ 3500197			
C9004	HR C,DE1005SL-221J2K	△ 3000115			
C9008	XJ C,QXJ2J-103K-TPT	△ 3000114			
C9009	IS C,DE1610E 472M-KX	3300052 <D>			
	CERA C,DE0910-1E102MKX	3300053S <T,P>			
C9010-C9014	PW C,CE04W16V-1000M(PW)	393741027			
C9015	ELECT C,CE04W50V-220M	354782219			
C9016	PW C,CE04W16V-470M(PW)	393744717			
C9017,C9018	ELECT C,CE04W25V-470M	354754719			
C9019	PW C,CE04W16V-470M(PW)	393744717			
C9020,C9021	ELECT C,CE04W25V-470M	354754719			
C9024	ELECT C,CE04W50V-100M	354781019			
C9029	PW C,CE04W16V-470M(PW)	393744717			
C9031,C9032	ELECT C,CE04W16V-470M	354744719			
C9042	PW C,CE04W16V-1000M(PW)	393741027			
C9043	IS C,DE1607F103M-KH	△ 3300031 <T,P>			
[RESISTOR]					
R9001	METAL PR,MPC74-5WK-0.22	△ 4000076			
R9002	METAL O R,RS2WBJ-0.22	△ 441722294F			
R9003	METAL O R,RS2WBJ-68K	△ 441726834NF			
R9004	METAL O R,RS1/2WBJ-680	443526814			
R9005	METAL O R,RS1/2WBJ-5.6K	443525624			
R9007	METAL O R,RS1/2WBJ-1K	443521024			
R9008	METAL O R,RS2WBJ-47K	△ 441724734F			
R9009	METAL O R,RS1/2WBJ-1K	443521024			
R9010	METAL O R,RS1/2WBJ-47	443524704			
R9011,R9012	METAL R,RNU1/2WCJ-1	453530104			
R9013-R9015	METAL R,RNU1/2WCJ-0.22	453532294			
R9016	METAL O R,RS1/2WBJ-10	443521004			
R9017	METAL R,RNU1/2WCJ-0.22	453532294			
R9019	METAL O R,RS1/2WBJ-270	443522714			
R9020	METAL O R,RS1/2WBJ-1.2K	443521224			
R9021	METAL O R,RS1/2WBJ-1.5K	443521524			
R9023	METAL O R,RS1/2WBJ-2.7K	443522724			

SAFETY-RELATED COMPONENT WARNING!!
 COMPONENTS IDENTIFIED BY MARK △ ARE CRITICAL FOR RISK OF FIRE AND ELECTRIC SHOCK.
 REPLACE THESE COMPONENTS WITH ONKYO PARTS WHOSE PART NUMBERS APPEAR AS SHOWN IN THIS MANUAL.

Note: <D>: 120V model only
 <P>: European model only
 <T>: Asian model only

ONKYO CORPORATION

Sales & Product Planning Div. : 2-1, Nisshin-cho, Neyagawa-shi, OSAKA 572-8540, JAPAN
Tel: 072-831-8111 Fax: 072-833-5222

ONKYO U.S.A. CORPORATION

18 Park Way, Upper Saddle River, N.J. 07458, U.S.A.
Tel: 201-785-2600 Fax: 201-785-2650 E-mail: onkyo@onkyousa.com

ONKYO EUROPE ELECTRONICS GmbH

Industriestrasse 20, 82110 Germering, GERMANY
Tel: 089-849-320 Fax: 089-849-3265 E-mail: info@onkyo.de

ONKYO CHINA LIMITED

Units 2102-2107, Metroplaza Tower I, 223 Hing Fong Road, Kwai Chung,
N.T., HONG KONG Tel: 852-2429-3118 Fax: 852-2428-9039



ONKYO SERVICE MANUAL

PCB Components Layout

Hard Disk Music Library MODEL MB-S1

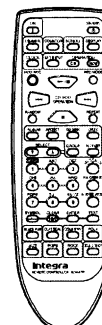
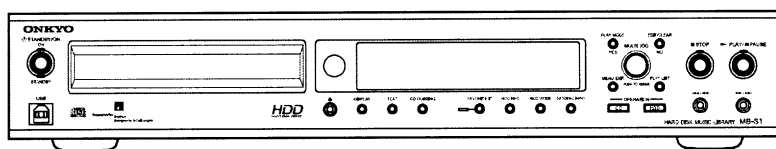

Black, Silver and Titanium models

BUDD	120V AC, 60Hz
TUUP,SUUT	120-240V AC, 50/60Hz

SAFETY-RELATED COMPONENT WARNING!!

COMPONENTS IDENTIFIED BY MARK  ON THE SCHEMATIC DIAGRAM AND IN THE PARTS LIST ARE CRITICAL FOR RISK OF FIRE AND ELECTRIC SHOCK.

REPLACE THESE COMPONENTS WITH ONKYO PARTS WHOSE PART NUMBERS APPEAR AS SHOWN IN THIS MANUAL.

MAKE LEAKAGE-CURRENT OR RESISTANCE MEASUREMENTS TO DETERMINE THAT EXPOSED PARTS ARE ACCEPTABLY INSULATED FROM THE SUPPLY CIRCUIT BEFORE RETURNING THE APPLIANCE TO THE CUSTOMER.

Main microprocessor version

01X04b

UDD ~#400

UUP ~#400

01X23A

Apply

UDD #401~

UUP #401~

A

B

C

D

E

PC BOARD VIEW - 1

U1:NAAR-7346 (Top Side View from Bottom Side)

1

2

3

4

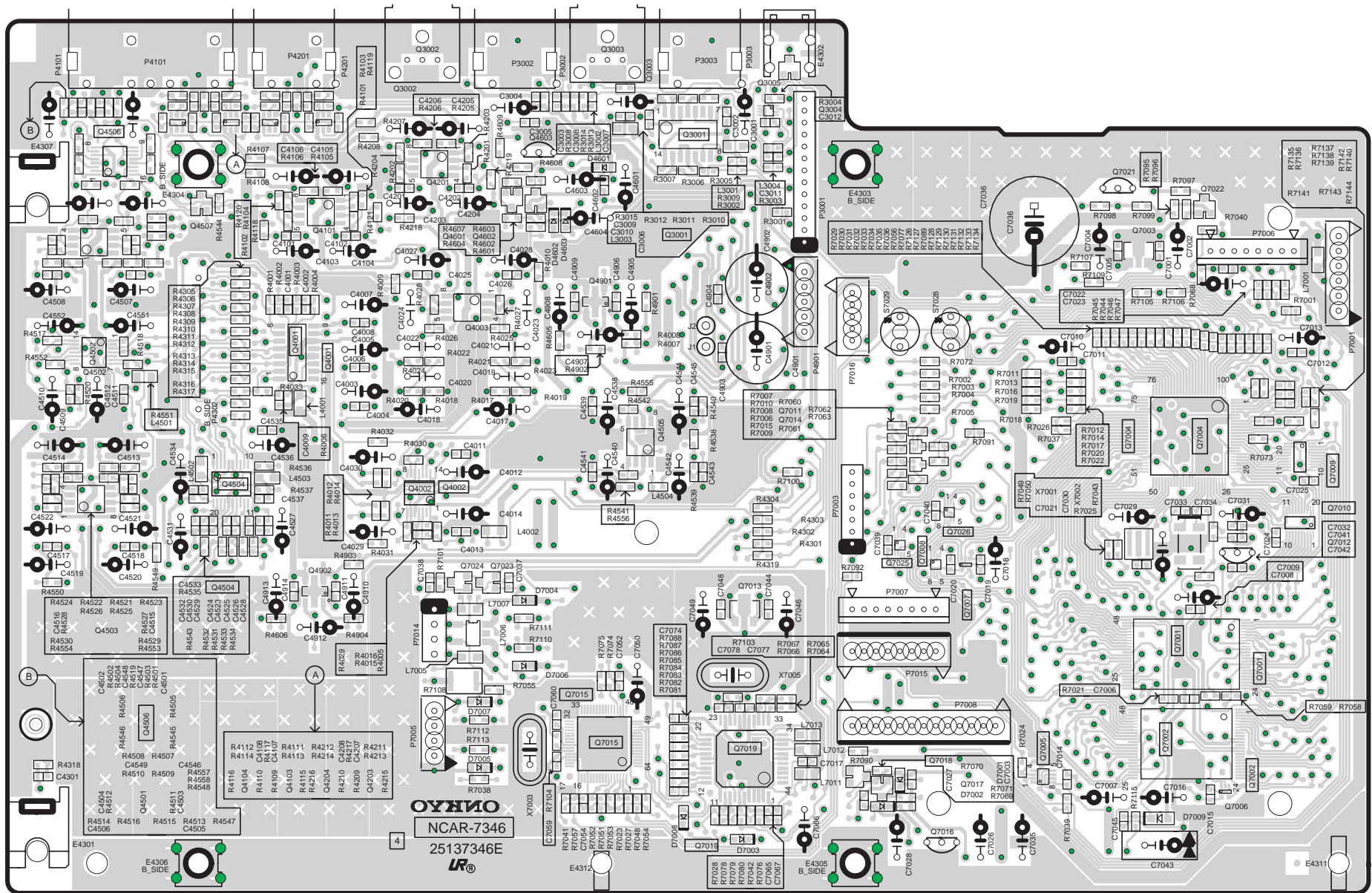

A

B

C

D

E

PC BOARD VIEW - 2
U1:NAAR-7346 (Bottom Side View from Top Side)

1

2

3

4

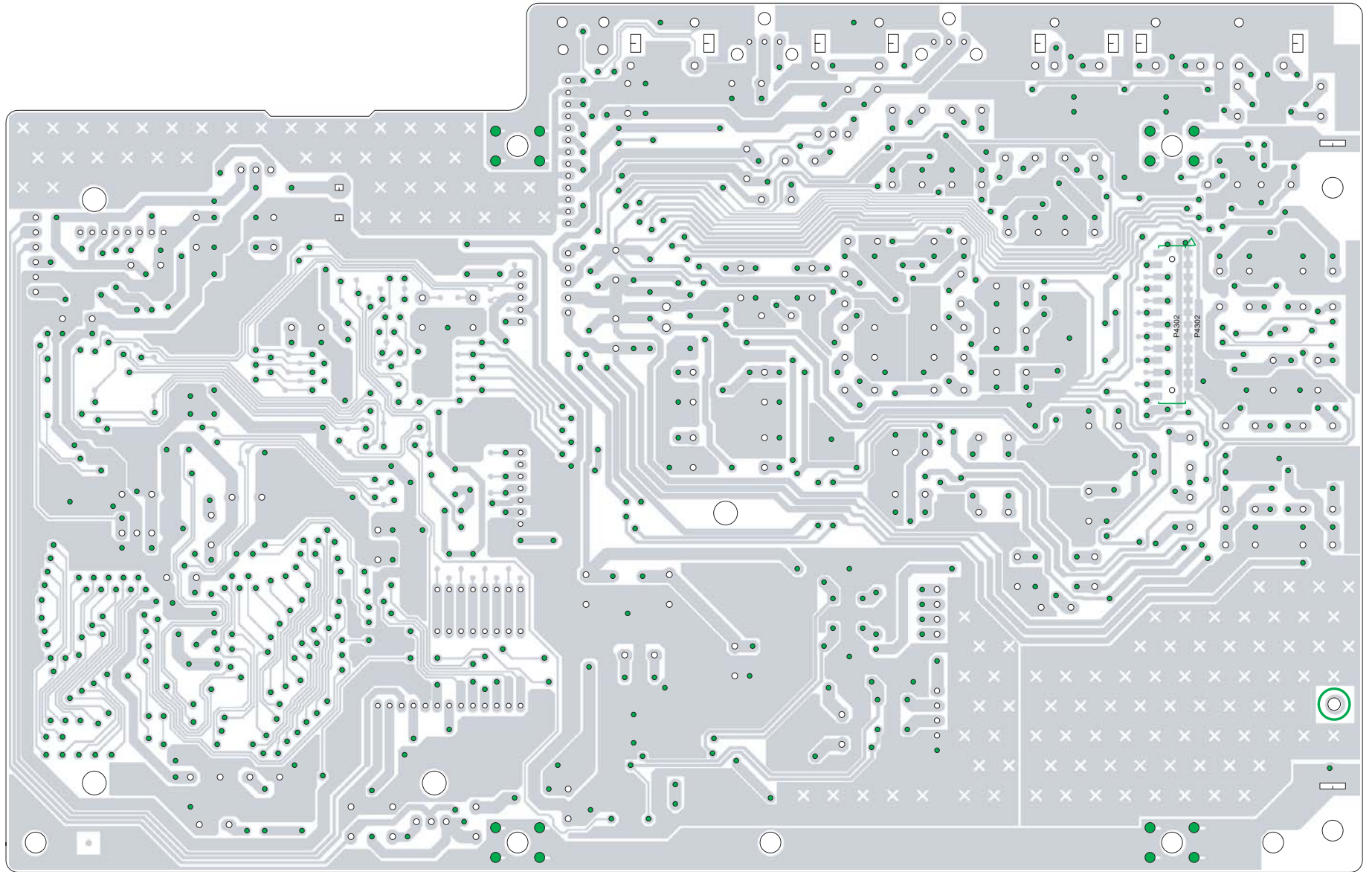

A

B

C

D

E

PC BOARD VIEW - 3

1

U2:NAETC-7347 (Top Side View from Bottom Side)

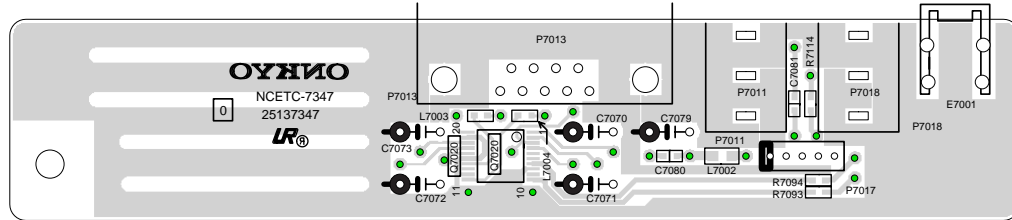

2

U3:NAETC-7348 (Top Side View from Bottom Side)

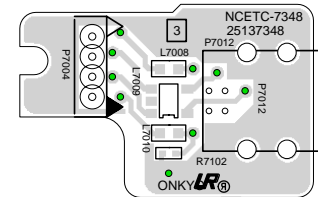

3

U2:NAETC-7347 (Bottom Side View from Top Side)

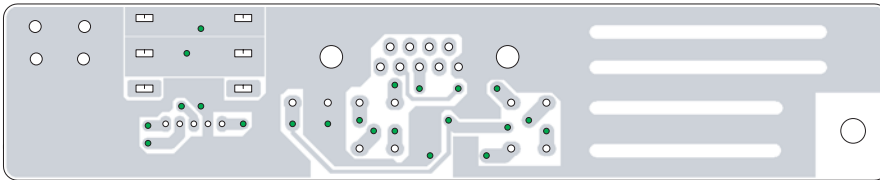

4

U3:NAETC-7348 (Bottom Side View from Top Side)

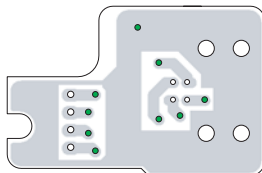

A

B

C

D

E

PC BOARD VIEW - 4 U4:NADIS-7349

(Bottom Side View from Top Side)

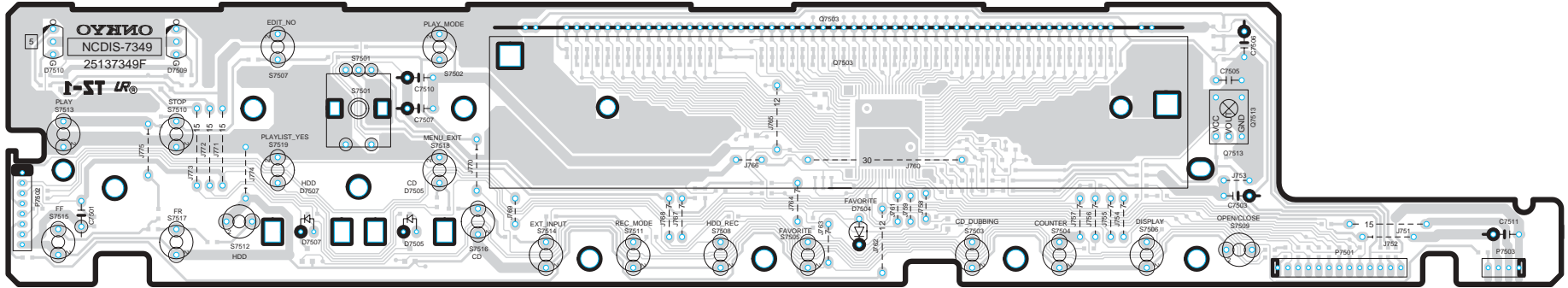

1

2

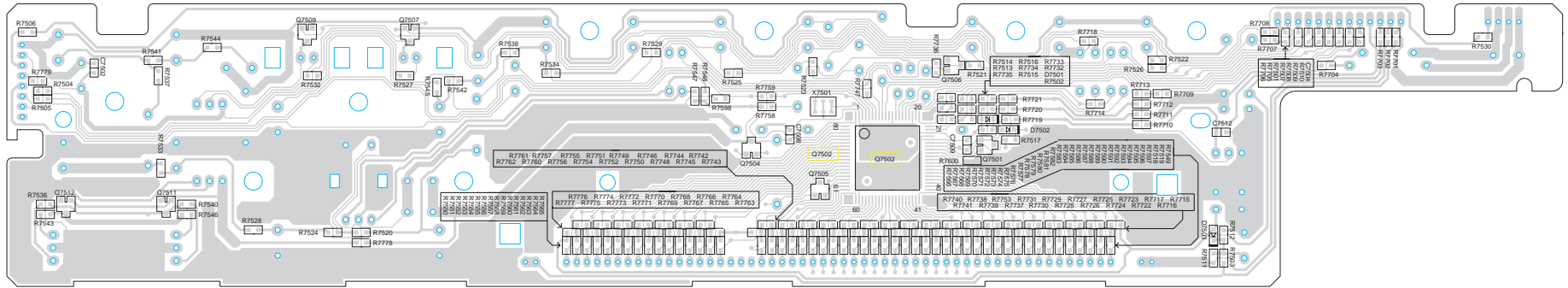

3

(Top Side View from Bottom Side)

4

A

B

C

D

PC BOARD VIEW - 5

U5:NAPS-7350 (Bottom Side View from Top Side)

1

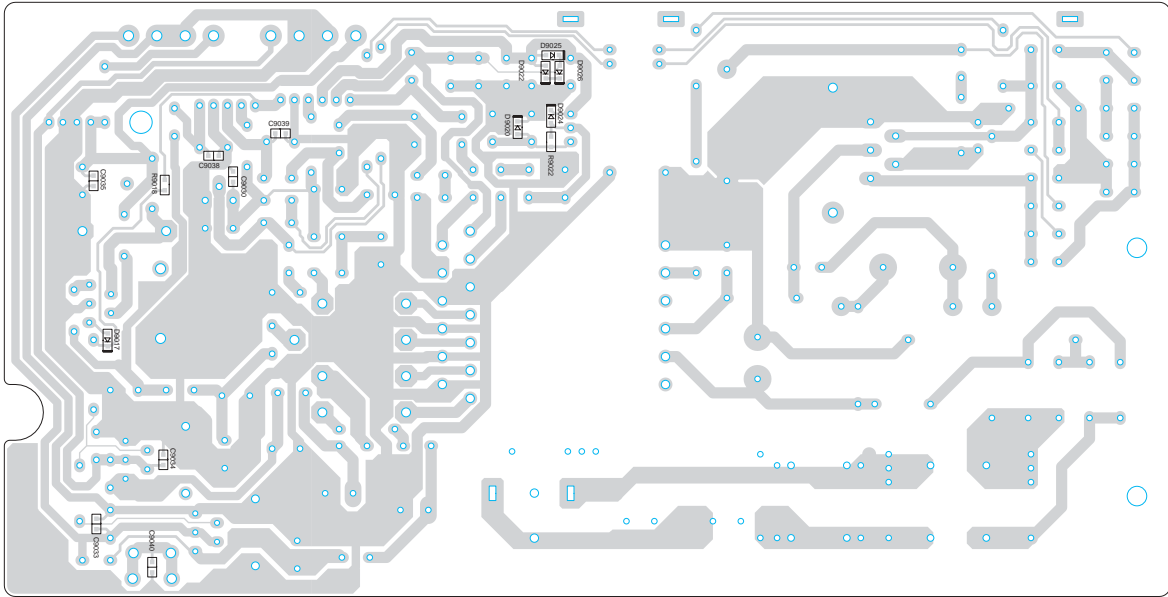

2

U5:NAPS-7350 (Top Side View from Bottom Side)

3

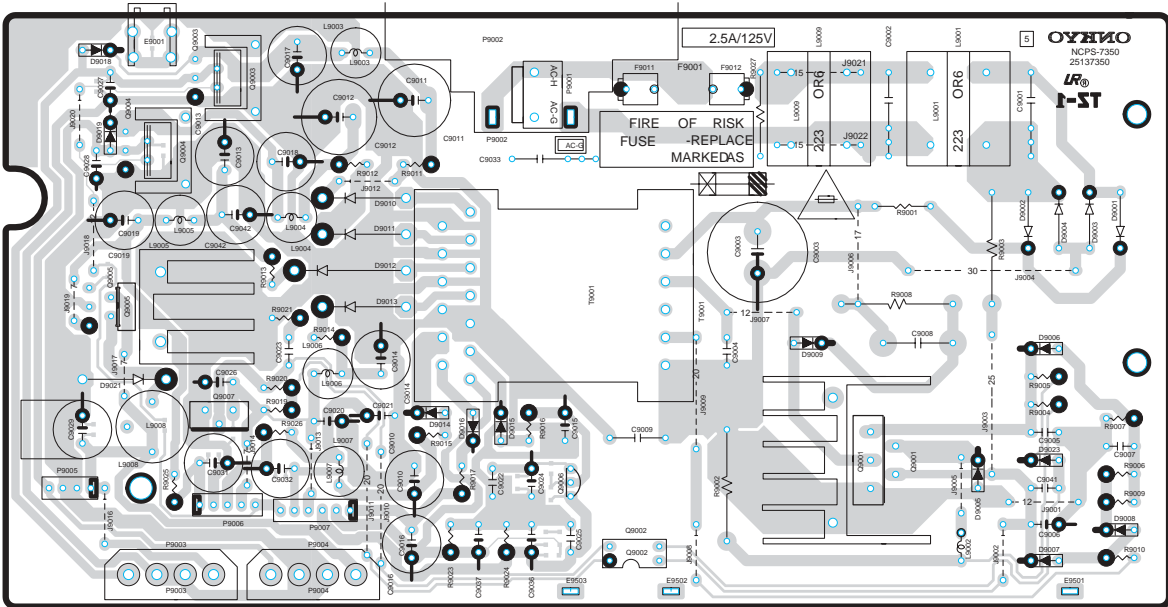

4

U6:NASW-7351

5

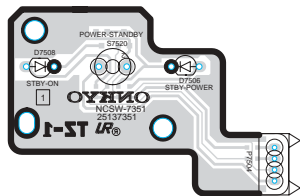

(Top Side View from Bottom Side)

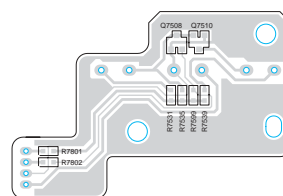

(Bottom Side View from Top Side)